



KANGAROO™
sewing furniture

ASSEMBLY INSTRUCTIONS

Mod 2081

ITEM NO.: 2081 White



General Assembly Guidelines

1. Read the instructions carefully before beginning the assembly process to ensure proper assembly of this product. Please open and inspect the contents of box(es) to see that all parts and hardware are included.

2. Tools Required



Phillips Screwdriver ⊕



Hammer



Electric Screwdriver ⊕
Torque set to 3-5

3. Understanding How the Cam Fastener Works

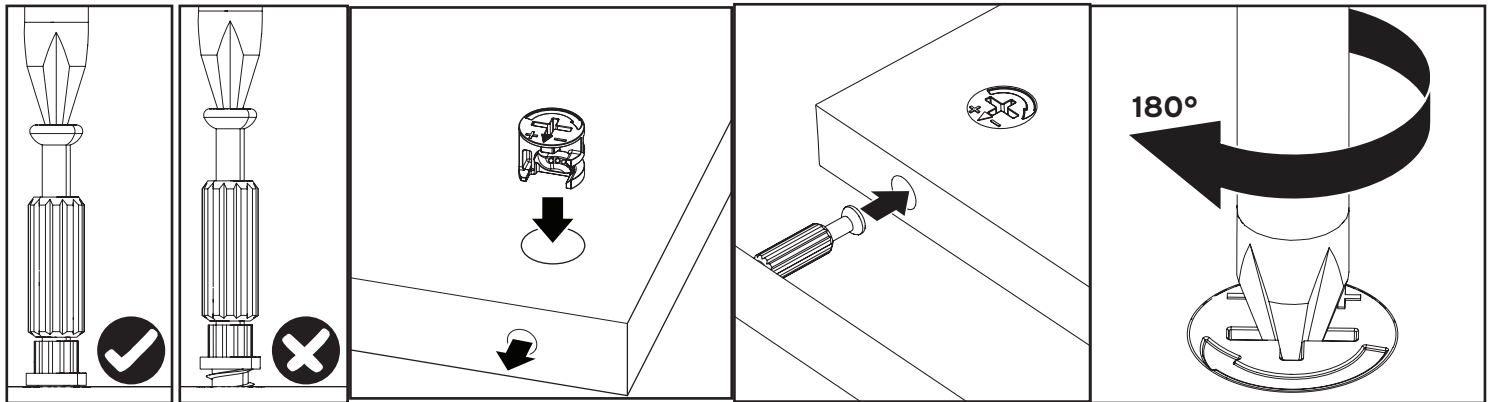

Screw cam bolts flush as illustrated.

Press cam into hole until flush with surface. The arrow direction must be in the direction of the hole.

Insert bolt through pre-drilled hole in edge of panel.

Turn clockwise to lock cam with bolt.

Tip: place a small bit of WD-40 or similar lubricant into the pre-installed cam bolt holes to help the cam bolts screw in better.

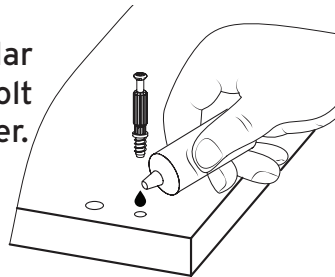

4. **Glue** provided is to secure wood dowels in place and is optional. If glue is used during assembly, locate the appropriate hole for the dowel, place a small amount of glue in the hole and insert the dowel. Wipe away excess glue immediately. It is not necessary to glue the other end of the dowel when attaching to other parts.

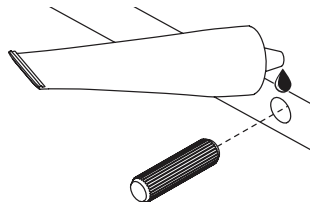

Use and Care Your cabinet normally requires a minimum amount of maintenance; however, the following points are worth noting:

Cleaning - To remove marks and enhance the surface, wipe with a gentle all-purpose cleanser. **DO NOT** use ammonia-based, harsh chemicals or abrasive cleaning agents. Wipe dry immediately.

Electrical and Hydraulic Lifts - Require annual lubrication with WD-40 or similar lubricant.

Parts List - Panels

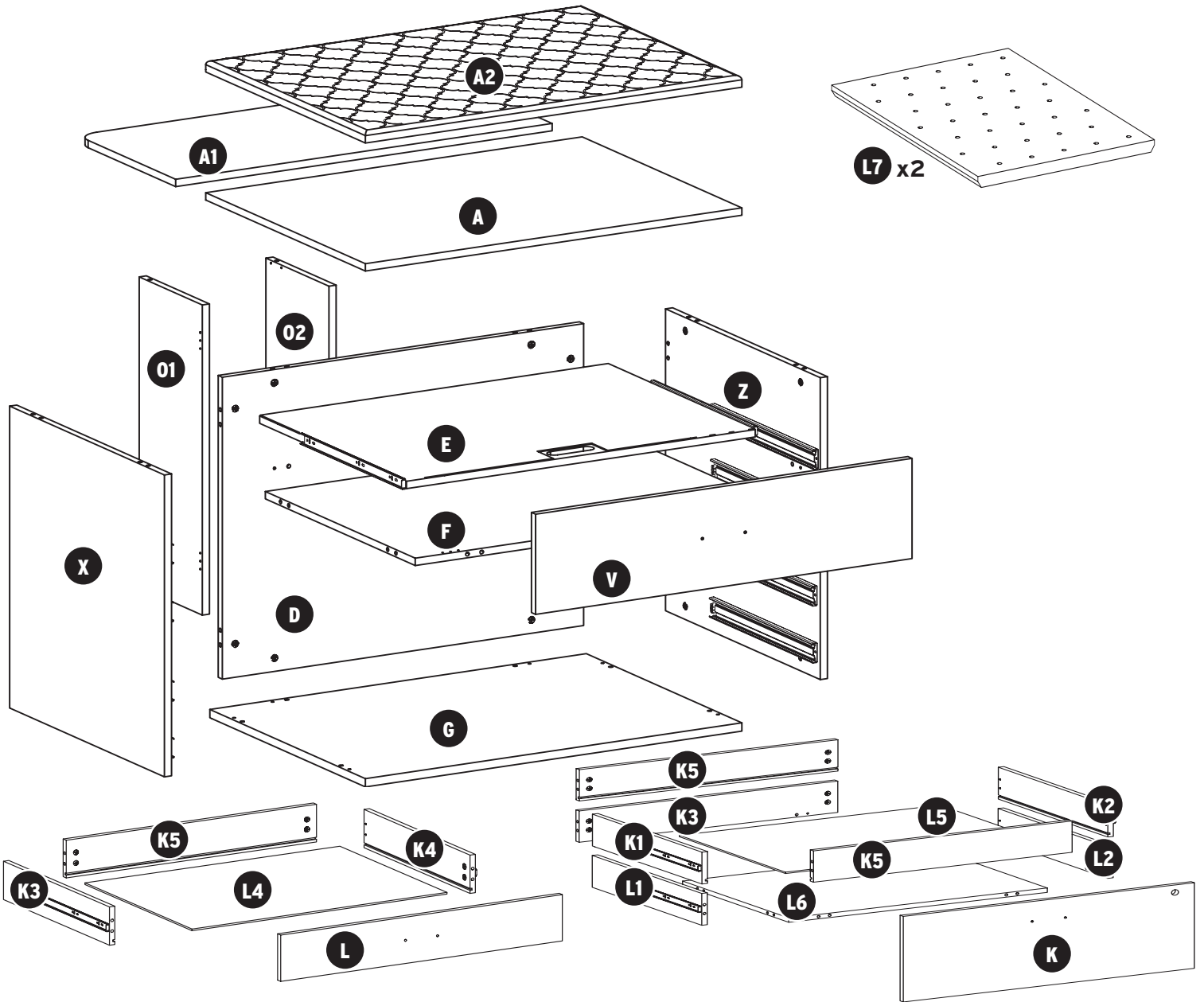

| ITEM | DESCRIPTION | QTY. | PACK. | ITEM | DESCRIPTION | QTY. | PACK. |
|------|---------------------|------|--------|------|----------------------------|------|--------|
| D | Back Panel | 1 | 1 of 3 | K5 | Top Drawer Back | 1 | 2 of 3 |
| F | Fixed Shelf | 1 | 1 of 3 | K3 | Top Drawer Right | 1 | 3 of 3 |
| X | Left Side Panel | 1 | 1 of 3 | K4 | Top Drawer Left | 1 | 3 of 3 |
| Z | Right Side Panel | 1 | 1 of 3 | L4 | Top Drawer Bottom | 1 | 3 of 3 |
| 01 | Left Gate Leg | 1 | 1 of 3 | L | Top Drawer Front | 1 | 3 of 3 |
| 02 | Right Gate Leg | 1 | 1 of 3 | K5 | Middle Drawer Front & Back | 2 | 3 of 3 |
| E | Pull Out Panel | 1 | 1 of 3 | K1 | Middle Drawer Left | 1 | 3 of 3 |
| A | Top Panel | 1 | 2 of 3 | K2 | Middle Drawer Right | 1 | 3 of 3 |
| A1 | Top Leaf Panel | 1 | 2 of 3 | L5 | Middle Drawer Bottom | 1 | 3 of 3 |
| A2 | Ironing Board Top | 1 | 2 of 3 | K3 | Bottom Drawer Back | 1 | 3 of 3 |
| G | Bottom Panel | 1 | 2 of 3 | L1 | Bottom Drawer Left | 1 | 3 of 3 |
| V | Door | 1 | 2 of 3 | L2 | Bottom Drawer Right | 1 | 3 of 3 |
| K | Bottom Drawer Front | 1 | 2 of 3 | L6 | Bottom Drawer Bottom | | |

Parts List: Hardware

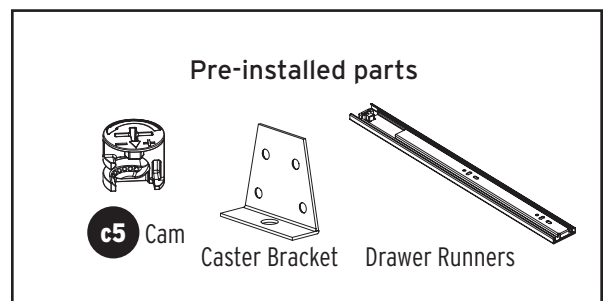
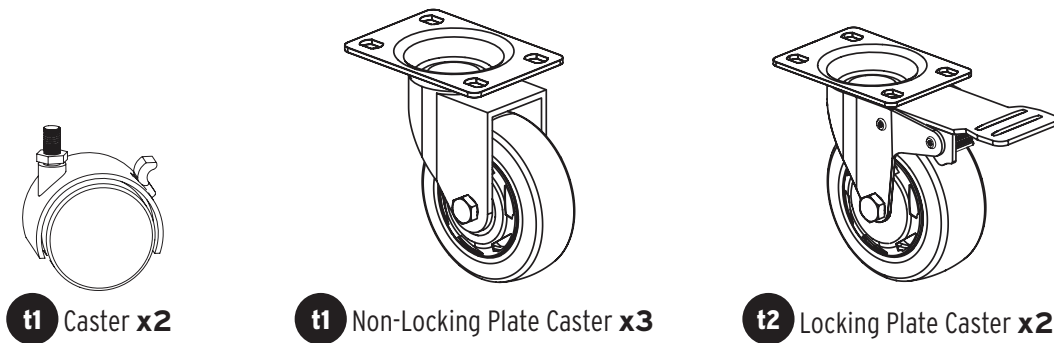
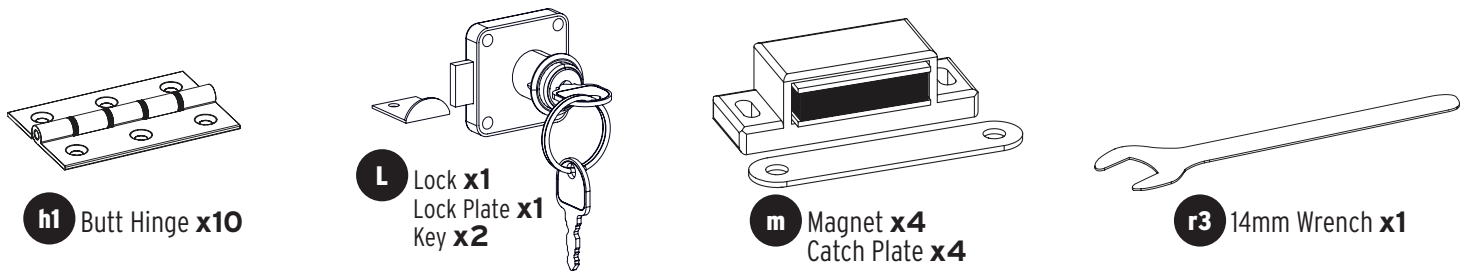

Part One: Cabinet Shell

We can't wait to get your brand new Mod 2081 Sewing Cabinet up and running. Please contact our Customer Service Team at 1-800-533-7347, ext. 1 during normal business hours with any assembly related questions.

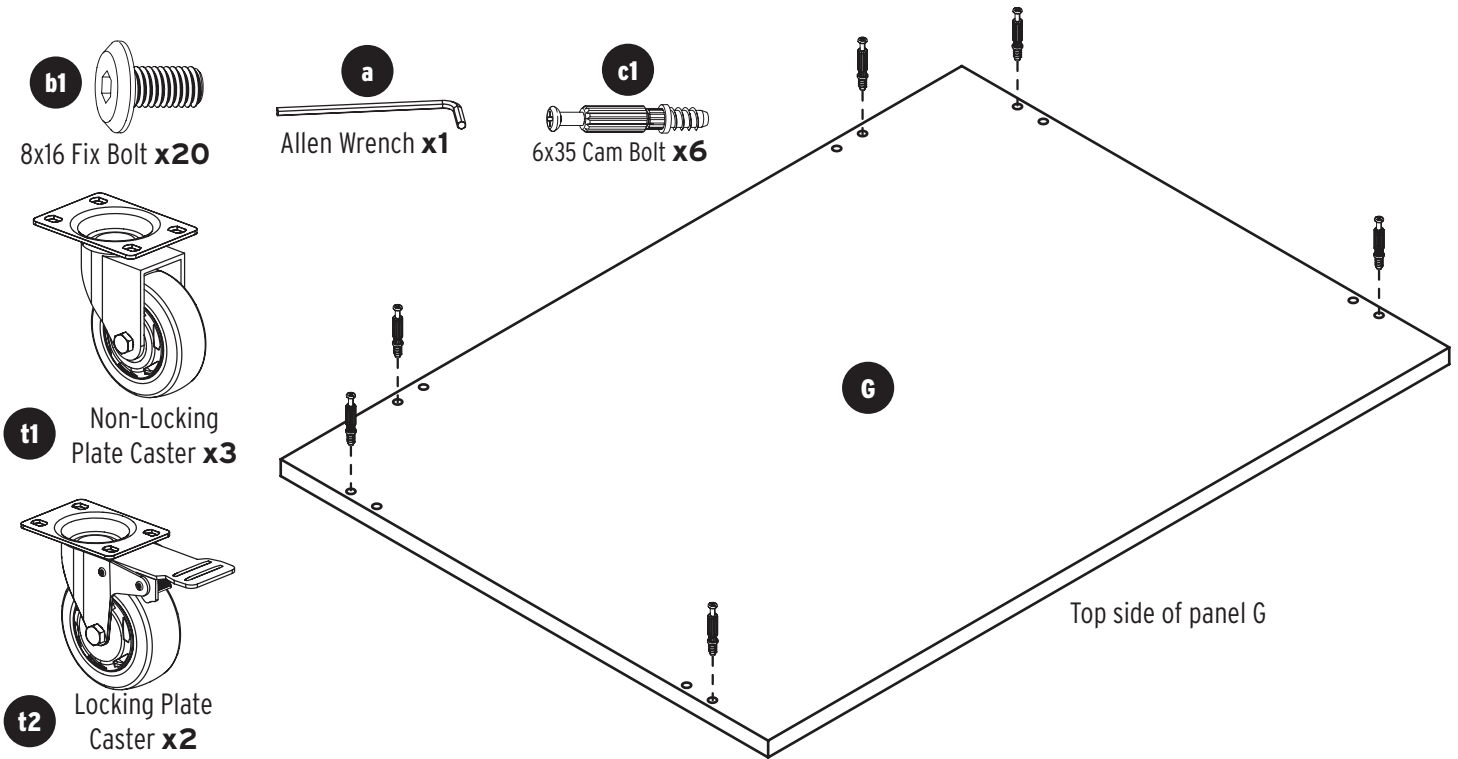

Install 6 **c1 Cam Bolts** into the top side of **Panel G**.

Flip **Panel G** over, and install **t2 Locking Plate Casters** at the front of the panel, and **t1 Non-Locking Plate Casters** at the middle and back of the panel, with **b1 Fix Bolts**.

Pay close attention to where the cam bolts are on the opposite side of the panel for correct caster placement.

Tighten with **Allen Wrench**.

Set **Panel G** aside.

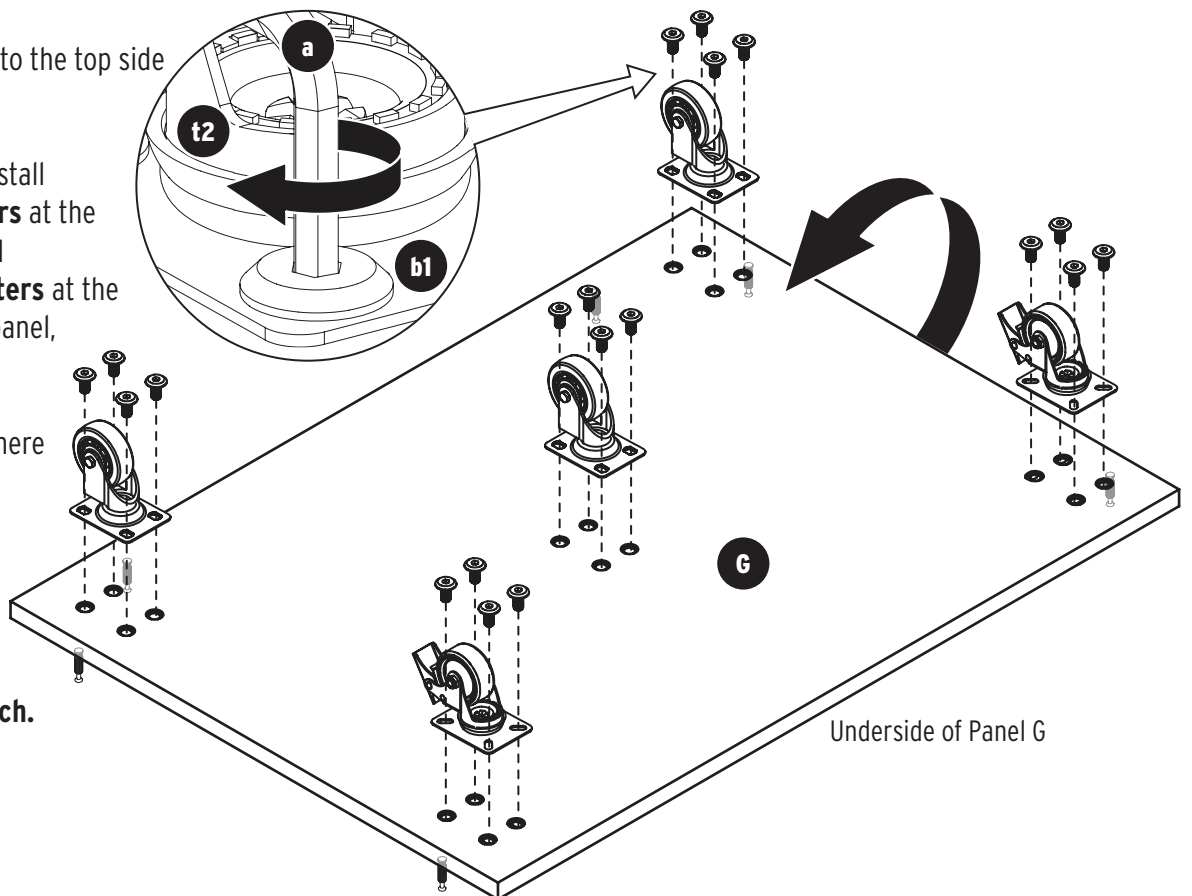

Part One: Cabinet Shell

c1

6x35 Cam Bolt **x10**

d1

8x30 Dowel Pin **x16**

L

Lock Plate **x1**

s1
3.5x14 Screw **x2**

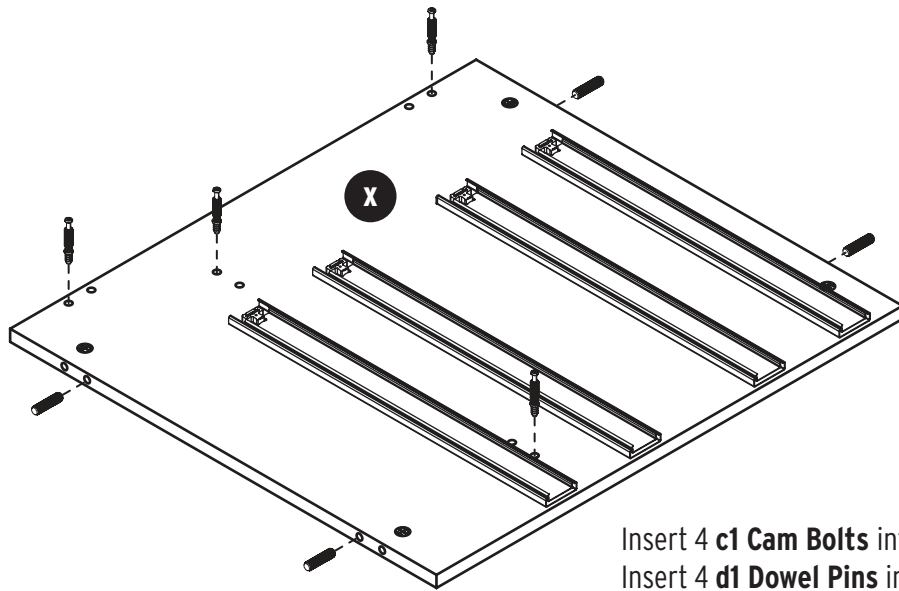

Insert 4 **c1** Cam Bolts into **Panel X**
Insert 4 **d1** Dowel Pins into **Panel X**

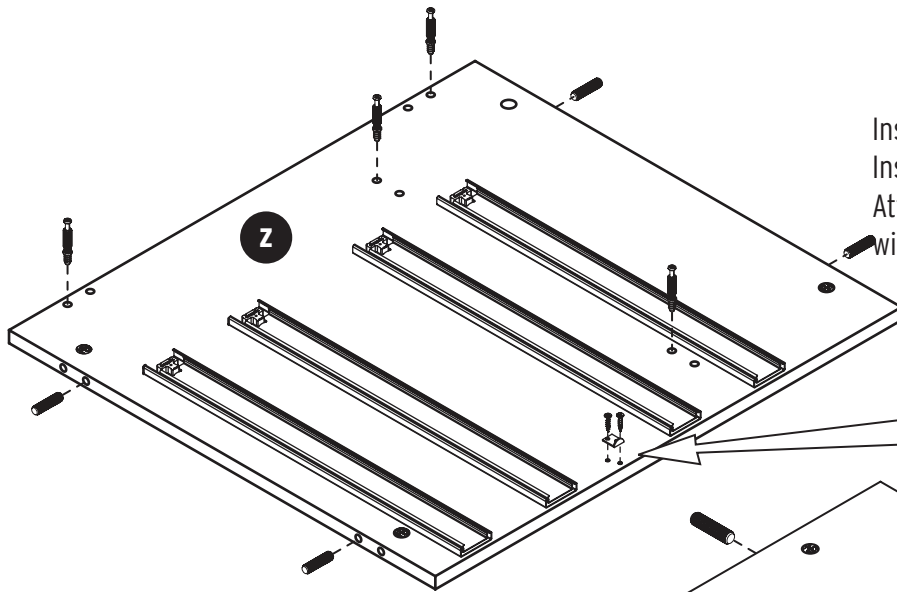

Insert 4 **c1** Cam Bolts into **Panel Z**
Insert 4 **d1** Dowel Pins into **Panel Z**
Attach **L** Lock Catch Plate to **Panel Z**
with **s1** Screws.

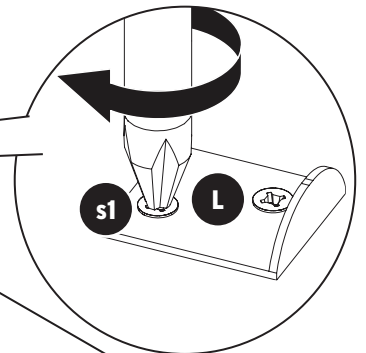

Insert 2 **c1** Cam Bolts
into **Panel D**.

Insert 8 **d1** Dowel Pins
into **Panel D**.

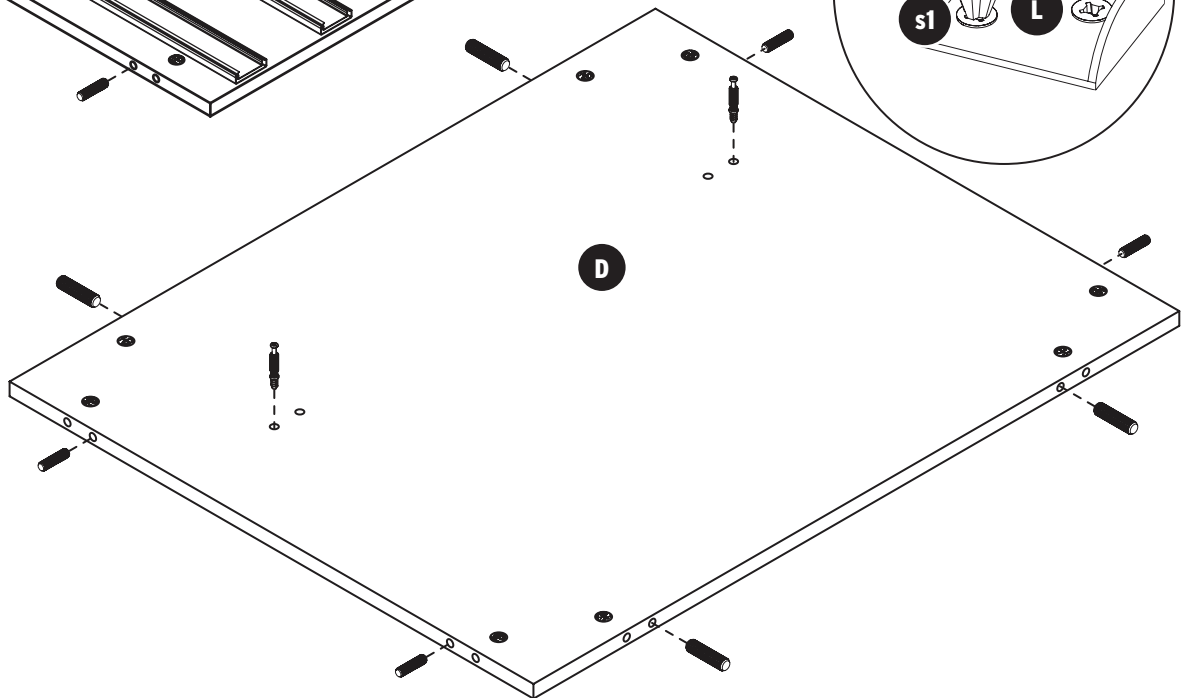

Part One: Cabinet Shell

d1



8x30 Dowel Pin x6

h1



Butt Hinge x3

s1



3.5x14 Screw x9

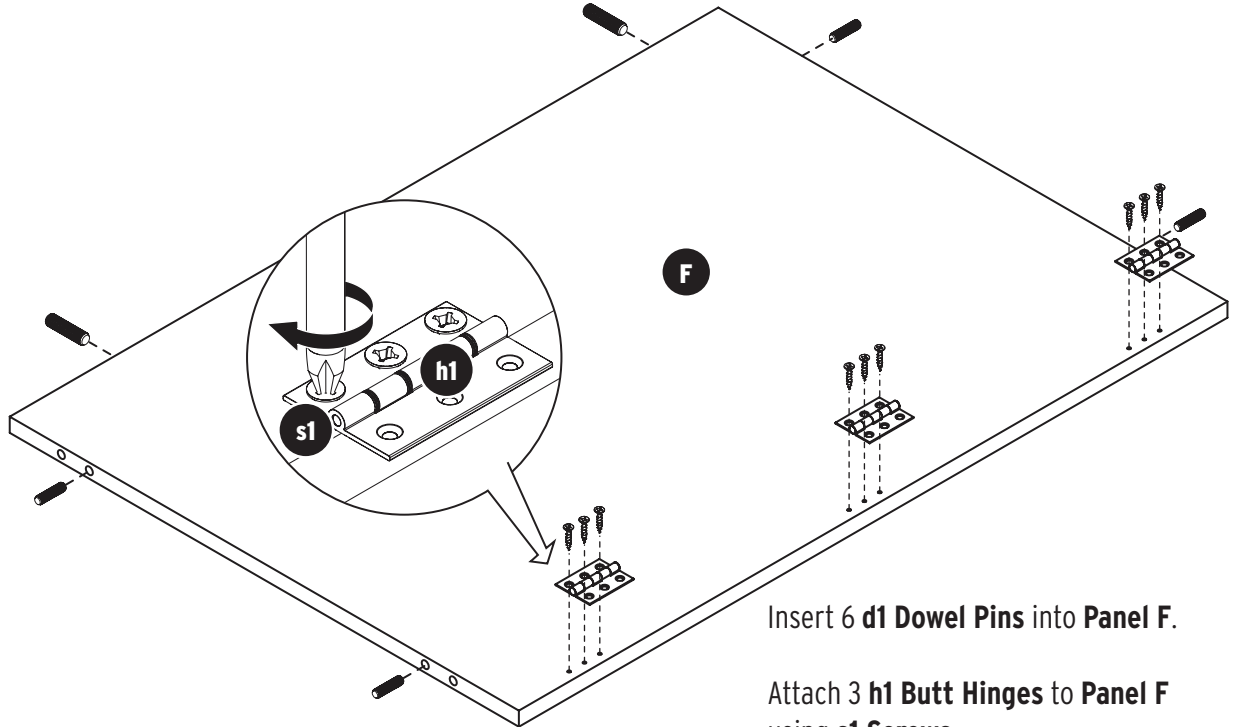

Insert 6 d1 Dowel Pins into Panel F.

Attach 3 h1 Butt Hinges to Panel F using s1 Screws.

c2



5/8" Cam Cover x2

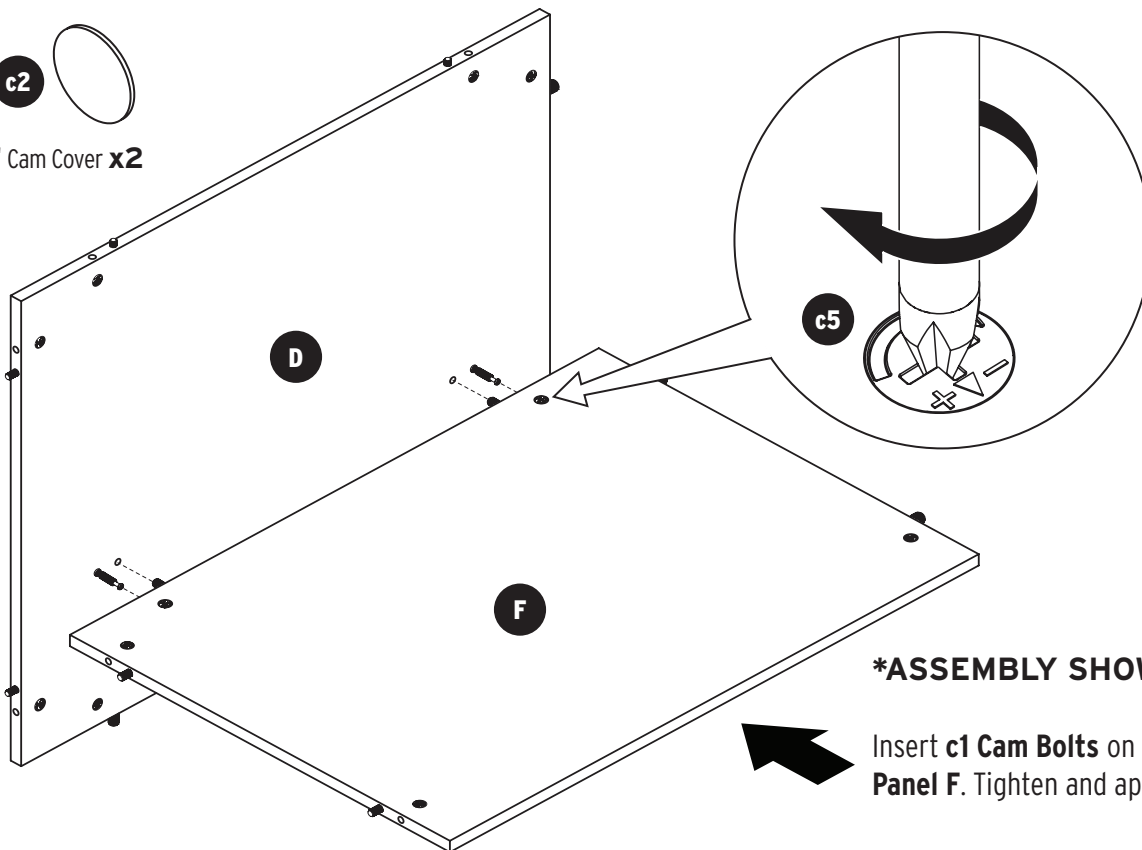

***ASSEMBLY SHOWN UPSIDE DOWN**

Insert c1 Cam Bolts on Panel D into cams on Panel F. Tighten and apply c2 Cam Covers.

Part One: Cabinet Shell



$\frac{5}{8}$ " Cam Cover x8

***ASSEMBLY SHOWN UPSIDE DOWN**

Insert **c1 Cam Bolts** on **Panels X and Z** into
cams on **Panels F and D**. Tighten and apply **c2**
Cam Covers.

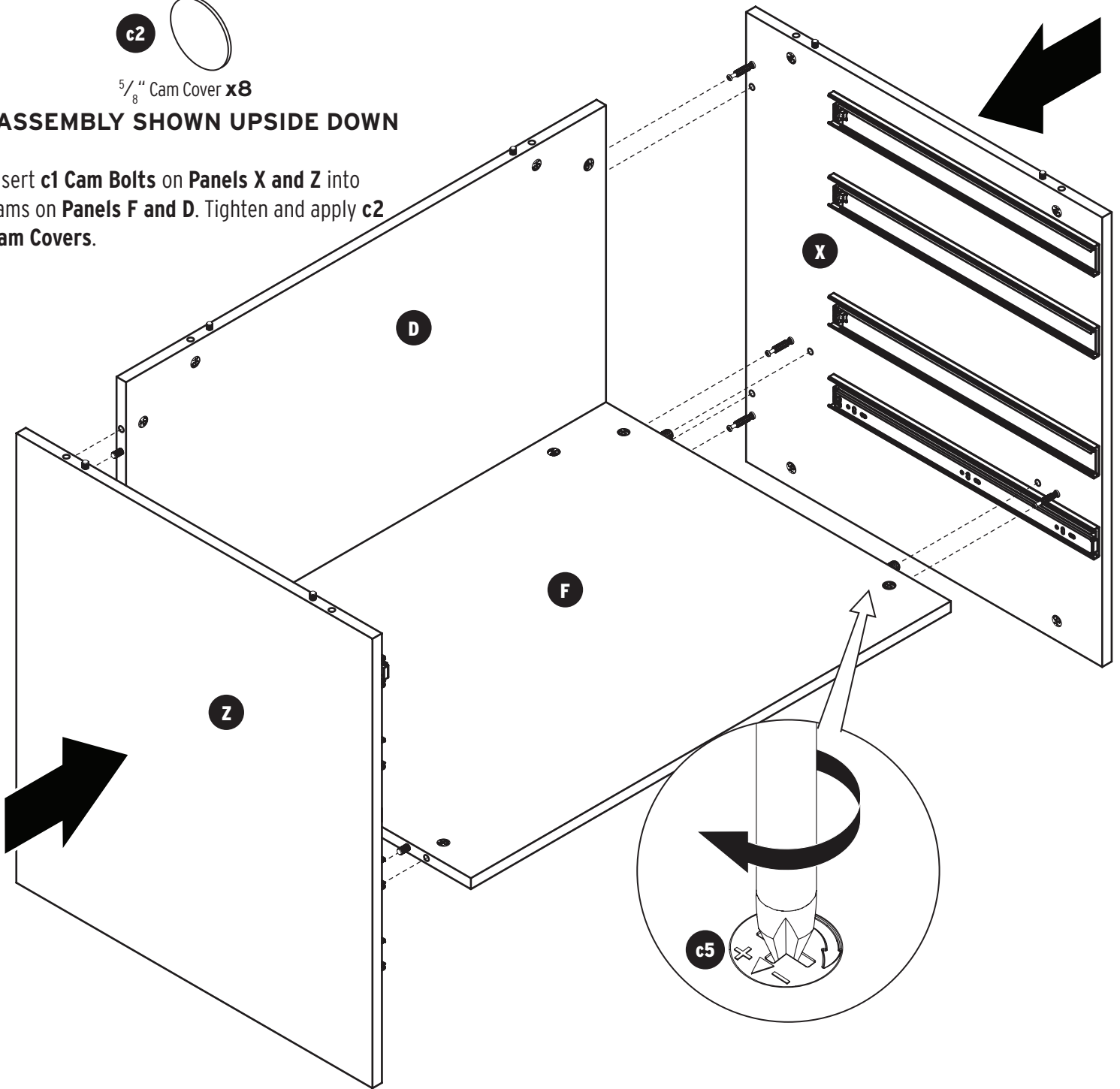

Part One: Cabinet Shell

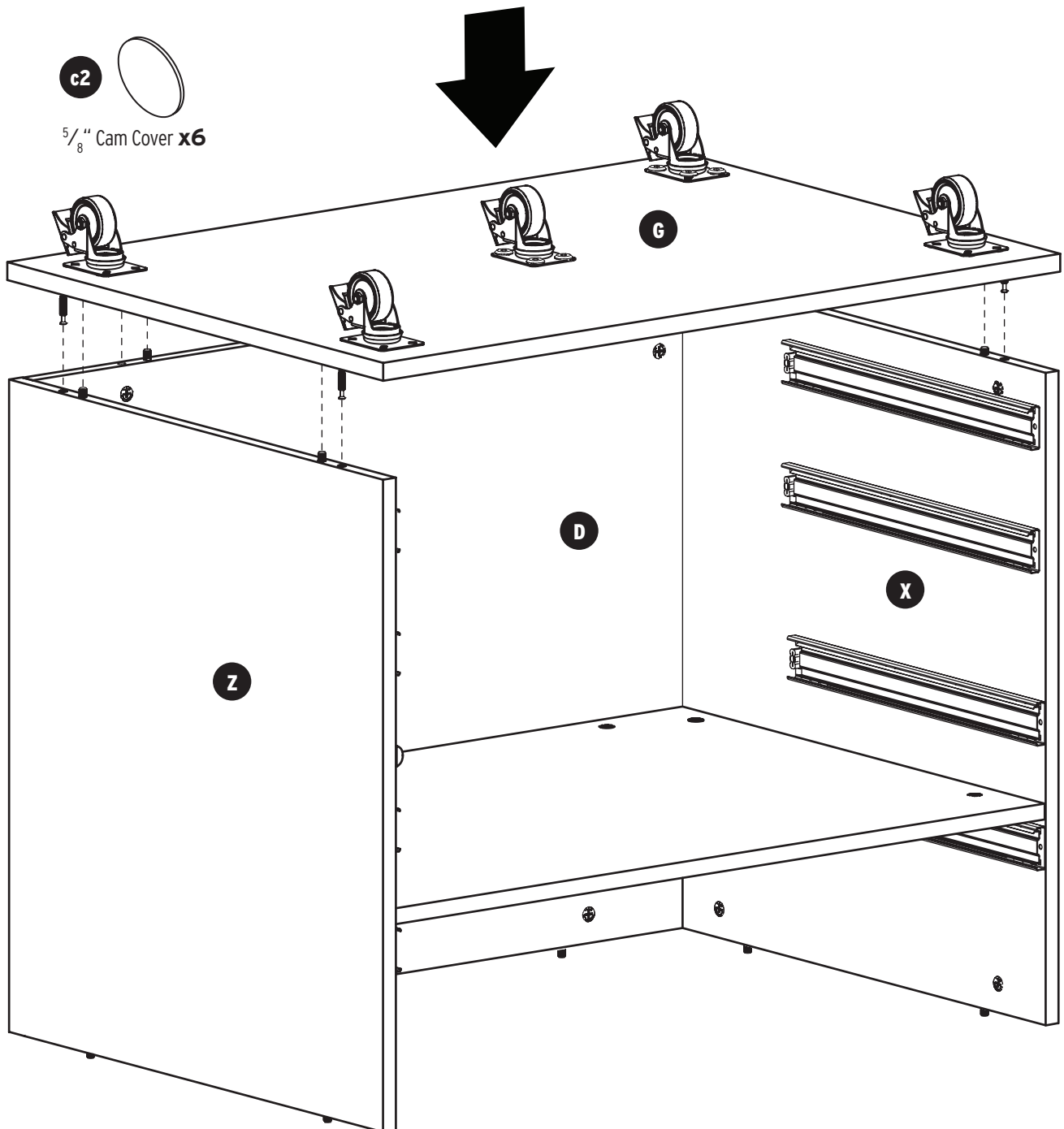

Insert **Cam Bolts** on **Panel G** into cams on **Panels X, Z and D**. Tighten and apply **Cam Covers**.

With the help of a friend, turn the cabinet over onto its casters.

Part One: Cabinet Shell

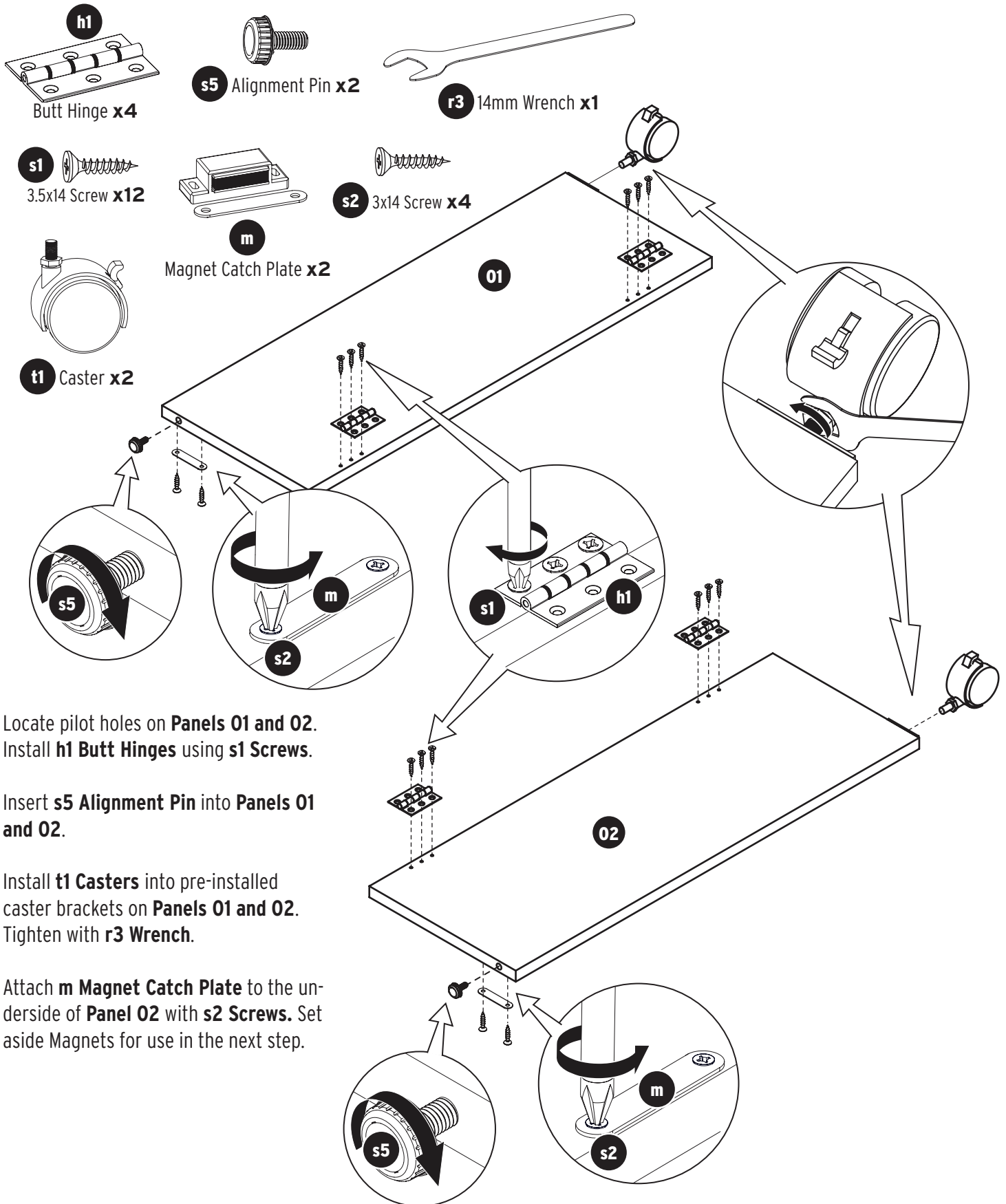

Locate pilot holes on **Panels 01 and 02**.
Install **h1 Butt Hinges** using **s1 Screws**.

Insert **s5 Alignment Pin** into **Panels 01 and 02**.

Install **t1 Casters** into pre-installed
caster brackets on **Panels 01 and 02**.
Tighten with **r3 Wrench**.

Attach **m Magnet Catch Plate** to the un-
derside of **Panel 02** with **s2 Screws**. Set
aside Magnets for use in the next step.

Part One: Cabinet Shell

s1 
3.5x14 Screw **x29**

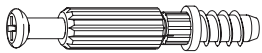

c1 6x35 Cam Bolt **x6**

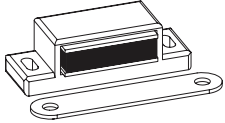

m Magnet **x4**

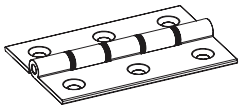

h1 Butt Hinge **x3**

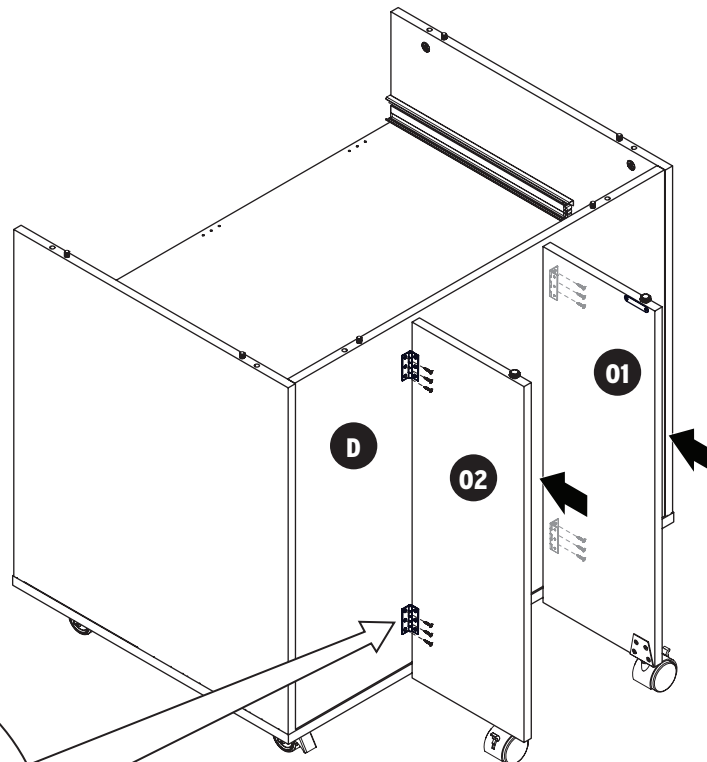

Locate the pilot holes on the back of **Panel D** and attach **h1 Butt Hinges** on **Panels 01 and 02** with **s1 Screws**.

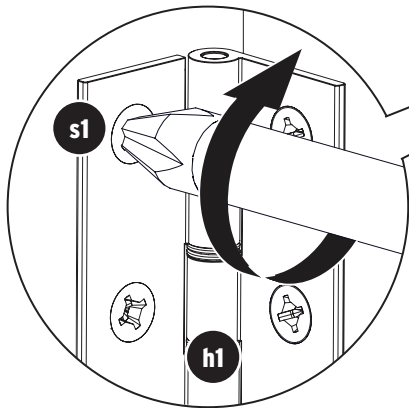

Insert **c1 Cam Bolts** into **Panel A**

Attach **m Magnets** to **Panel A** with **s1 Screws**.

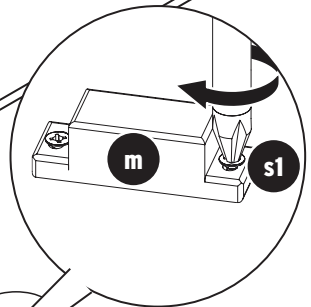
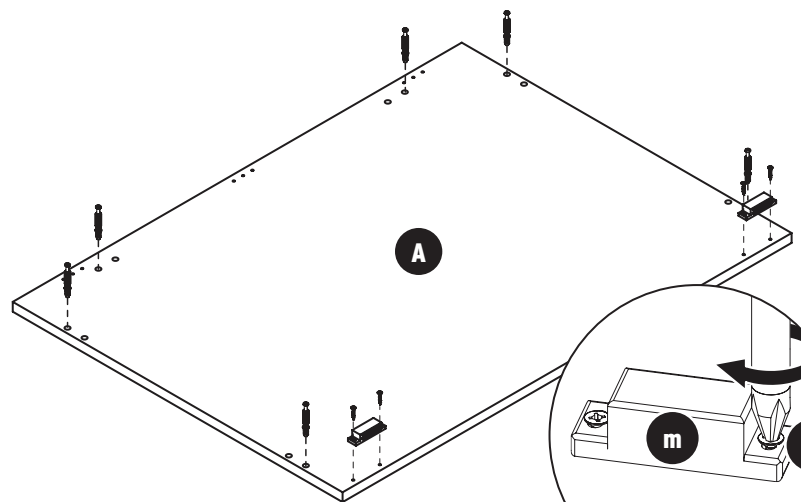

Locate pilot holes in **Panel A1**. Attach **h1 Butt Hinges** to **Panel A1** with **s1 Screws**.

Attach **m Magnets** to **Panel A1** with **s1 Screws**.

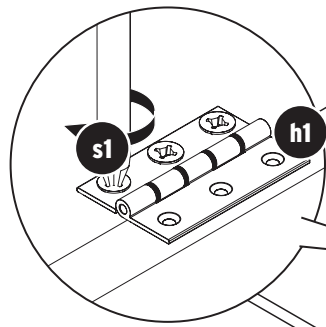
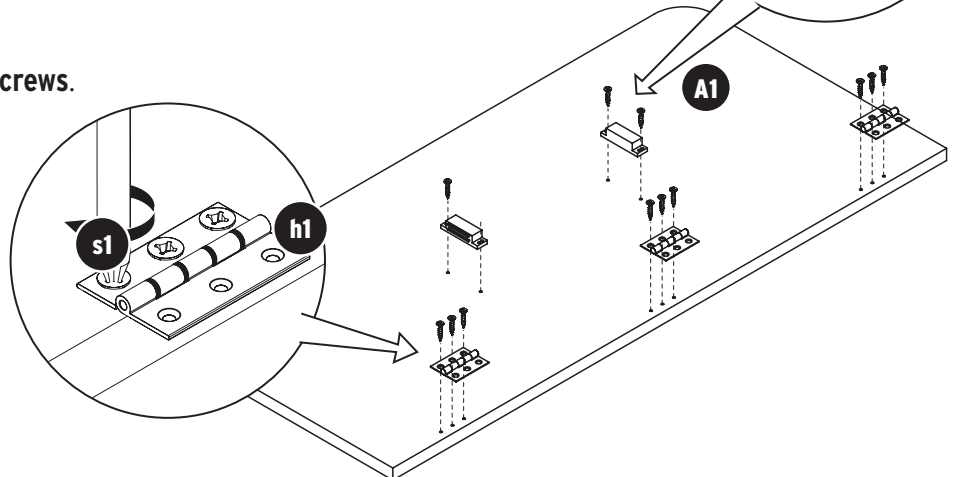

Part One: Cabinet Shell

s1  3.5x14 Screw **x9**

c2  $\frac{5}{8}$ " Cam Cover **x6**

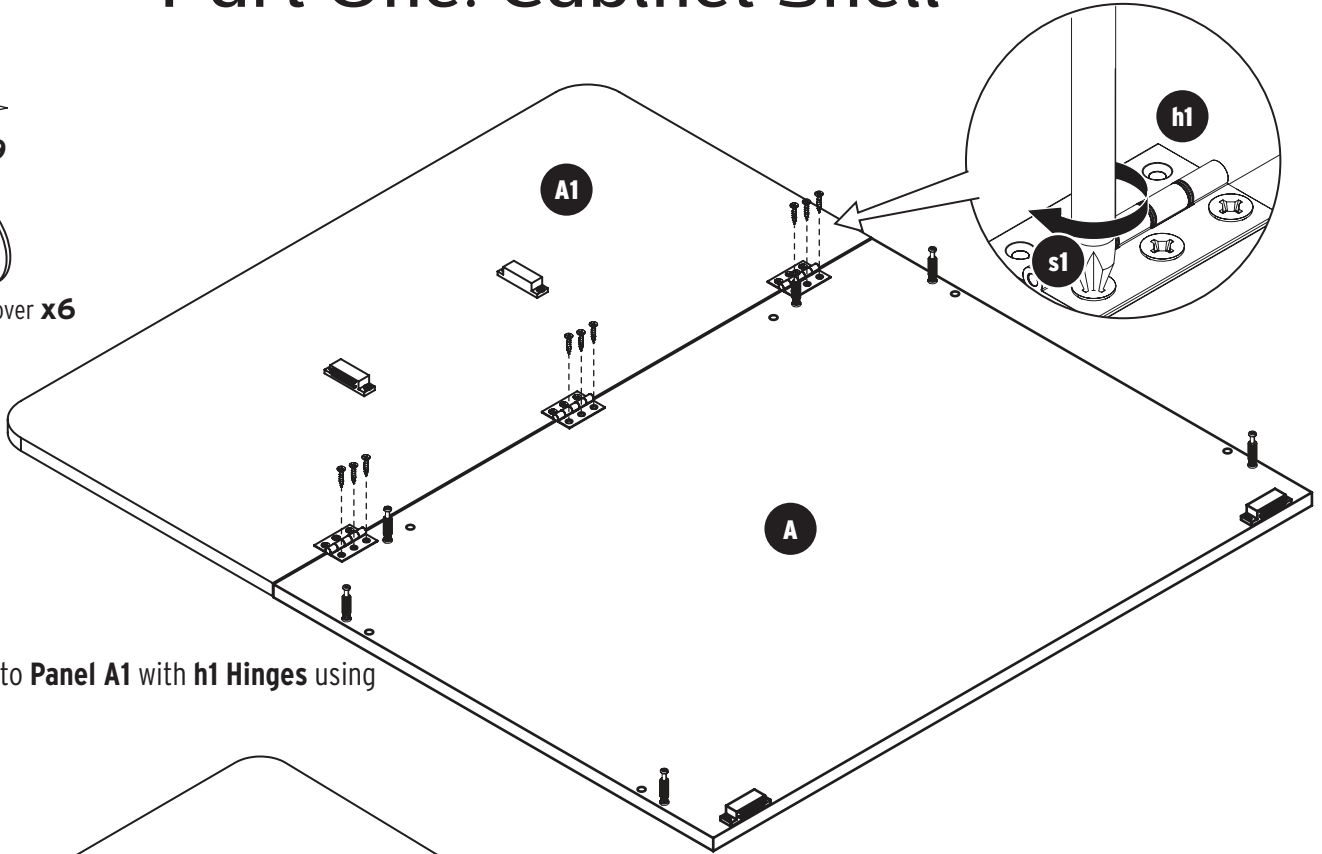

Attach **Panel A** to **Panel A1** with **h1 Hinges** using **s1 Screws**.

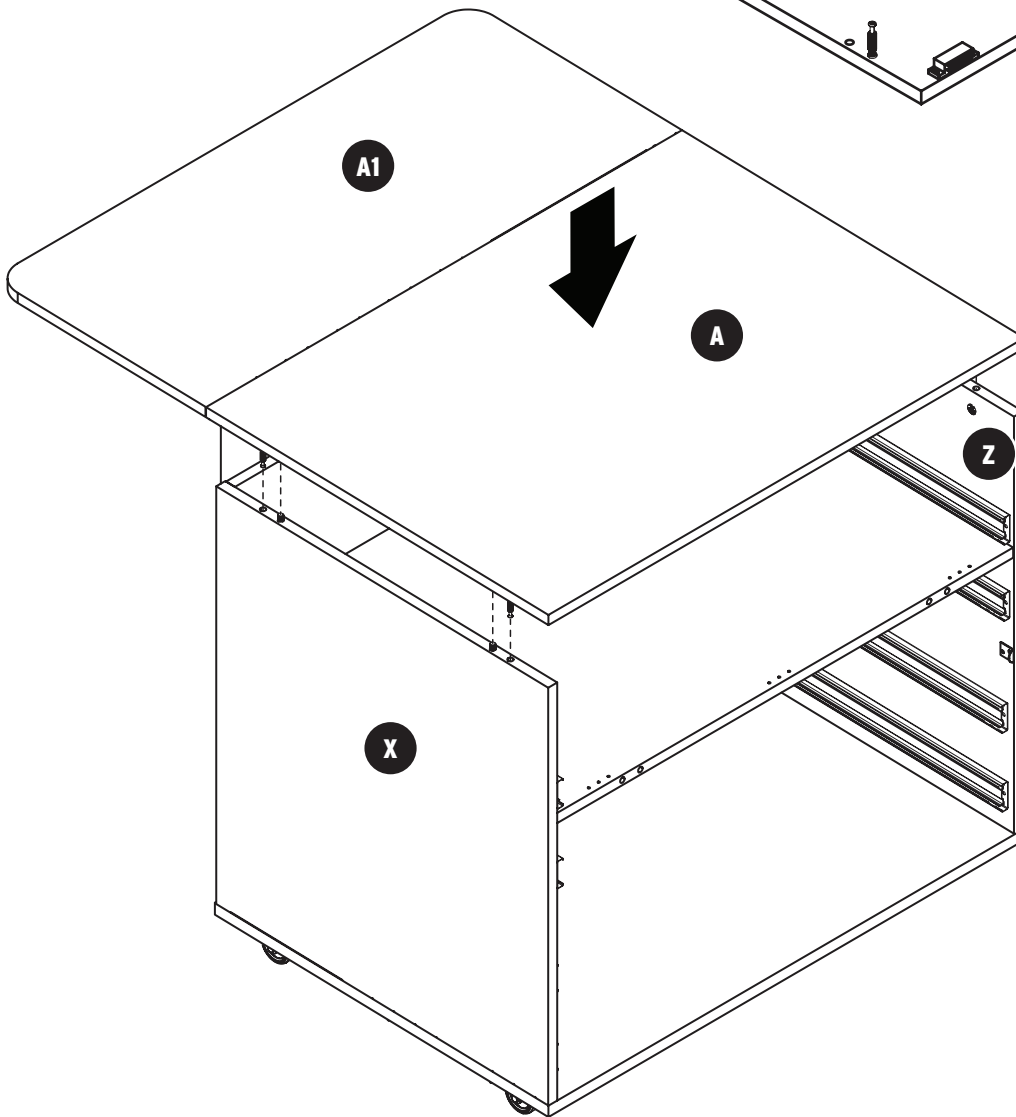

Lower top **Panels A/A1** onto cabinet, using **Panels O1** and **O2** for support, while inserting Cam Bolts into **Panels D, X** and **Z**.
Tighten and apply **Cam Covers**.

Part Two: Drawers - Bottom Drawer

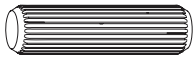

d1 8x30 Dowel Pin **x8**

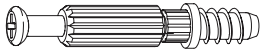

c1 6x35 Cam Bolt **x16**

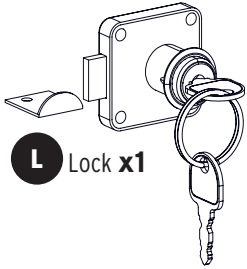

L Lock **x1**



s4 3.5x20 Screw **x4**

Insert 8 **d1** Dowel Pins into the edges of **Panel L6**

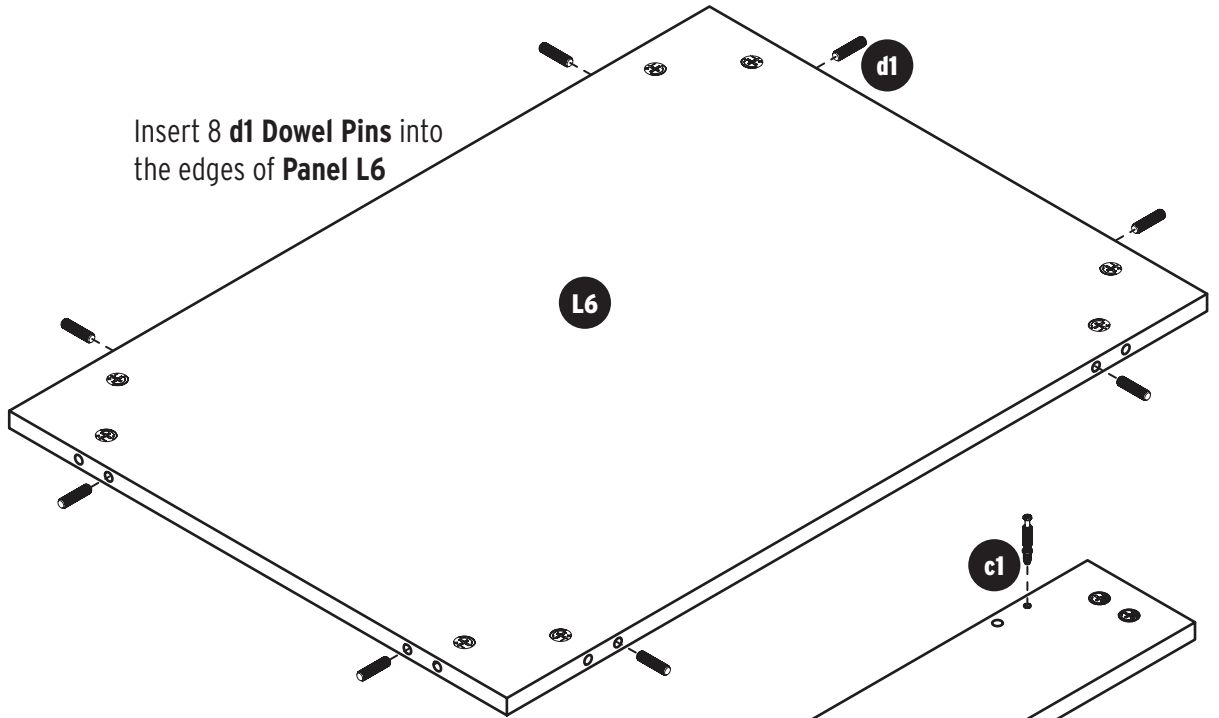

Attach 2 **c1** Cam Bolts to **Panel L3**.

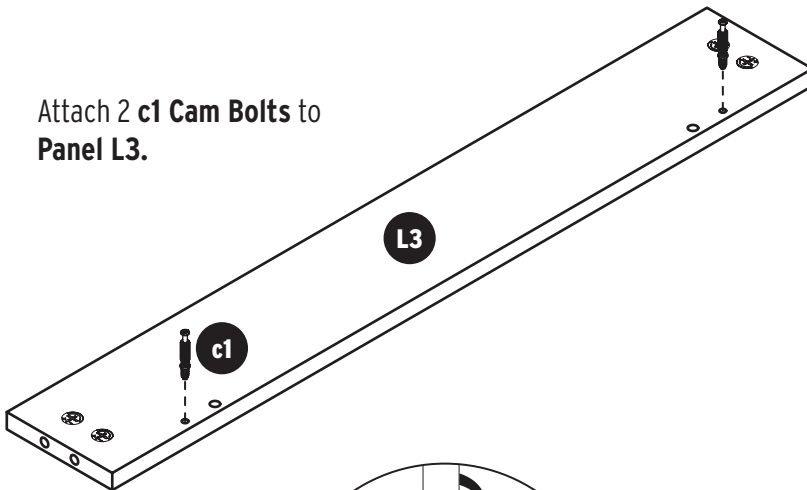

Attach 4 **c1** Cam Bolts into each drawer side panel (**Panels L1 and L2**).

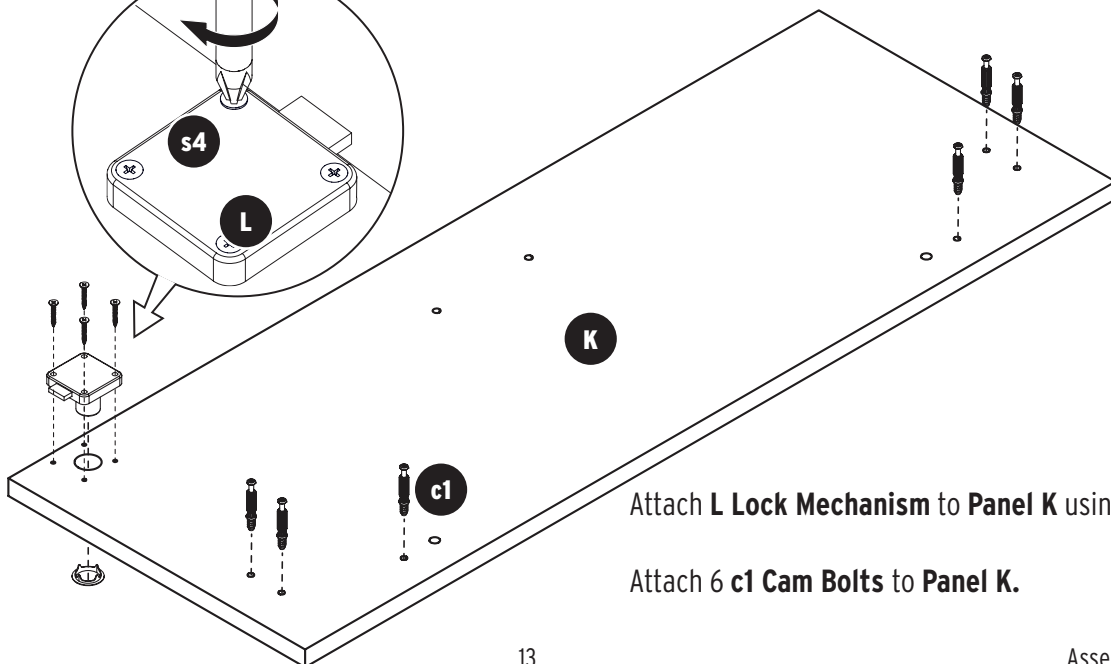
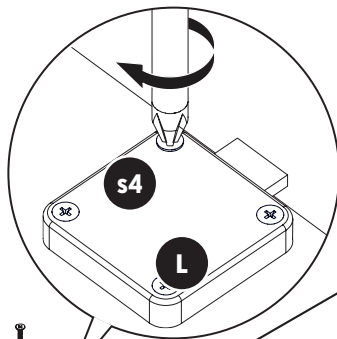
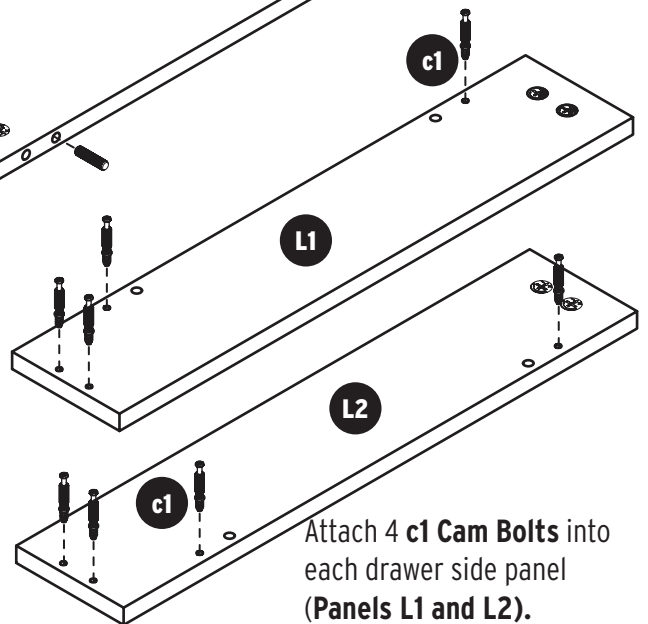

Attach **L** Lock Mechanism to **Panel K** using 4 **s4** screws.

Attach 6 **c1** Cam Bolts to **Panel K**.

Part Two: Drawers - Bottom Drawer



NOTE: Cam Locks on **Panel L6** should be facing down, as illustrated.

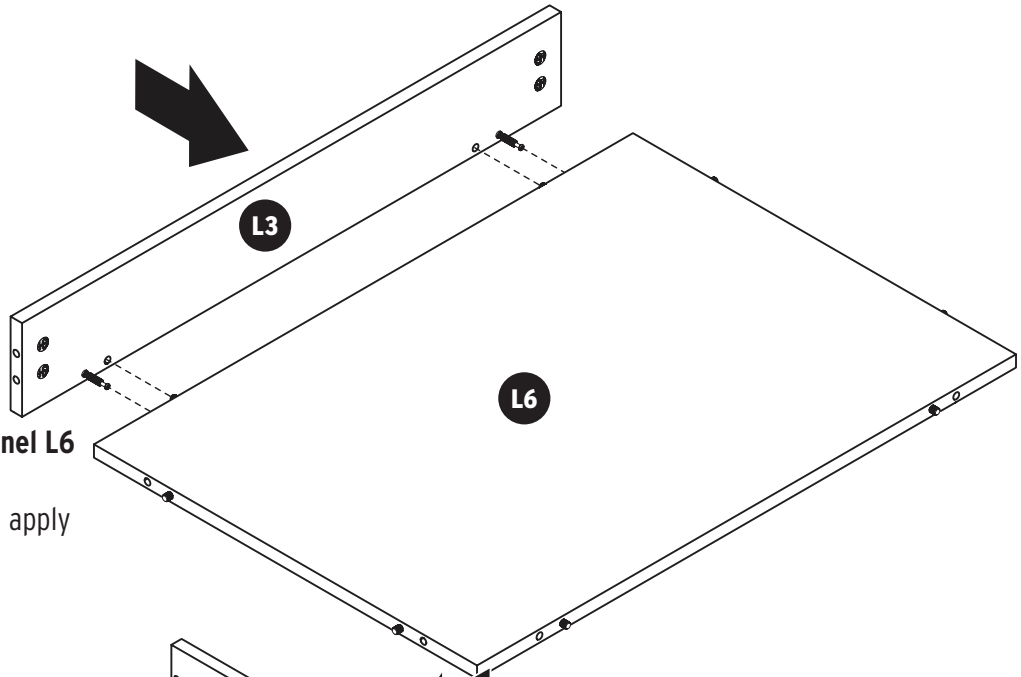

Attach **Panel L3** to **Panel L6** as shown.
Tighten cam locks and apply **c2 Cam Covers**.

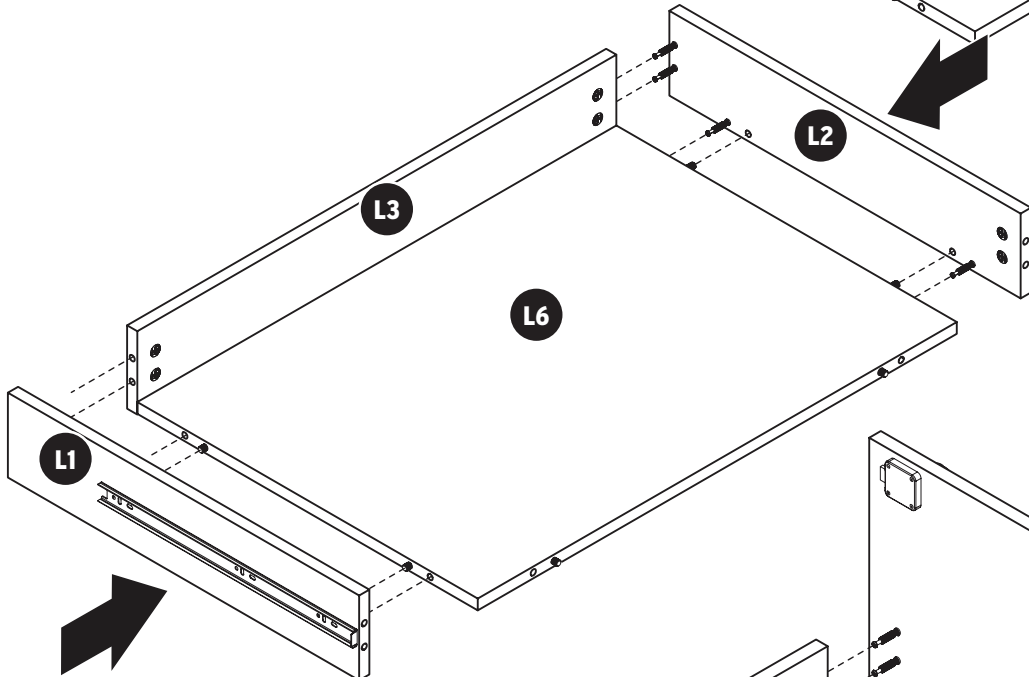

Attach **Panels L1 and L2** to **Panels L3 and L6** as shown.
Tighten cam locks and apply **c2 Cam Covers**.

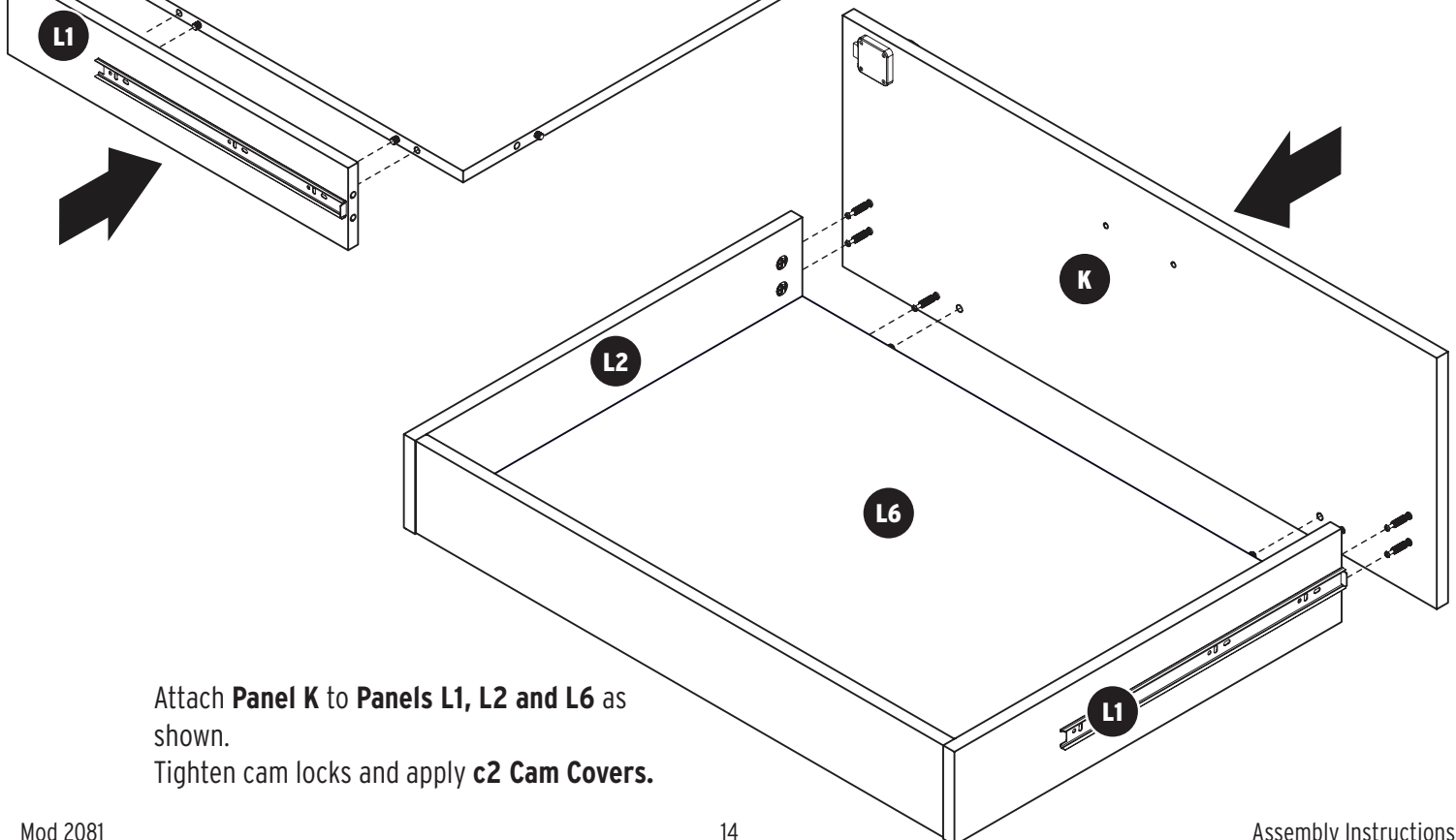

Attach **Panel K** to **Panels L1, L2 and L6** as shown.
Tighten cam locks and apply **c2 Cam Covers**.

Part Two: Drawers - Middle Drawer

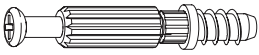

c1 6x35 Cam Bolt **x8**



c2 5/8" Cam Cover **x4**

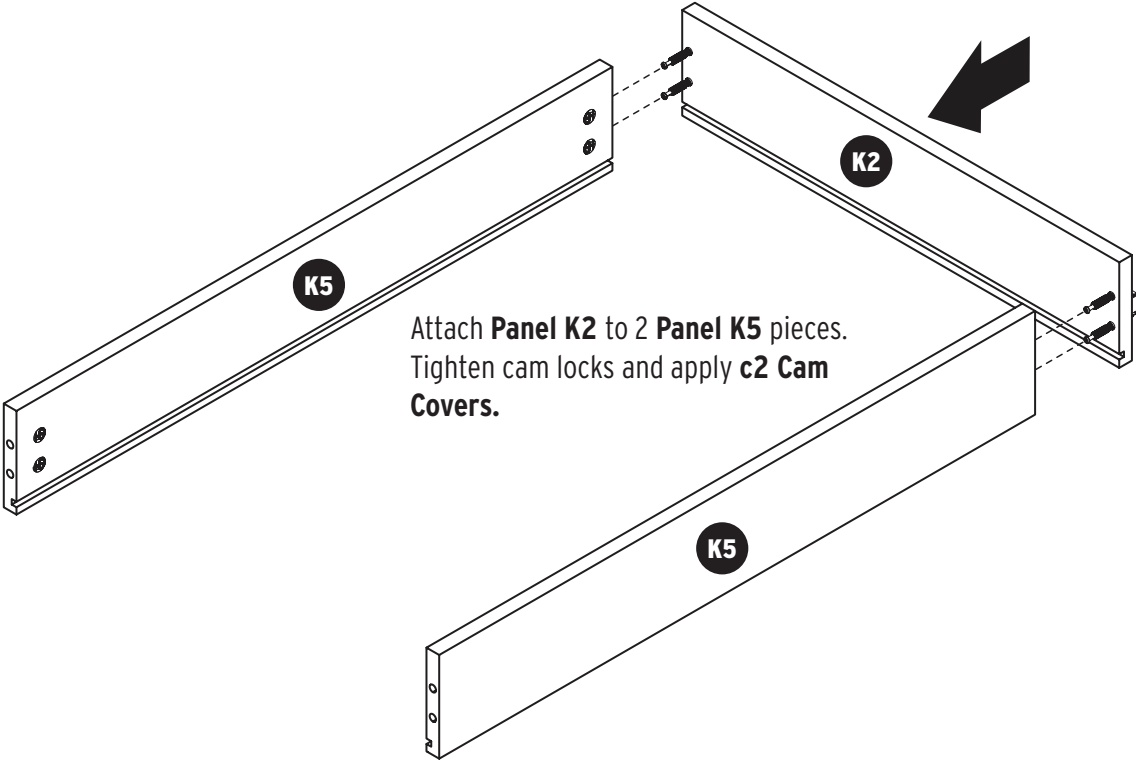
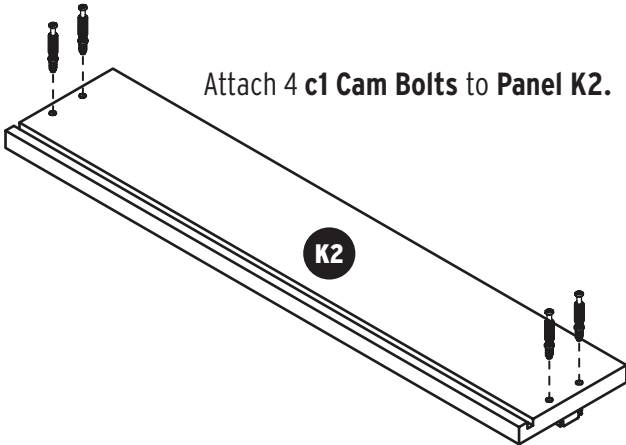
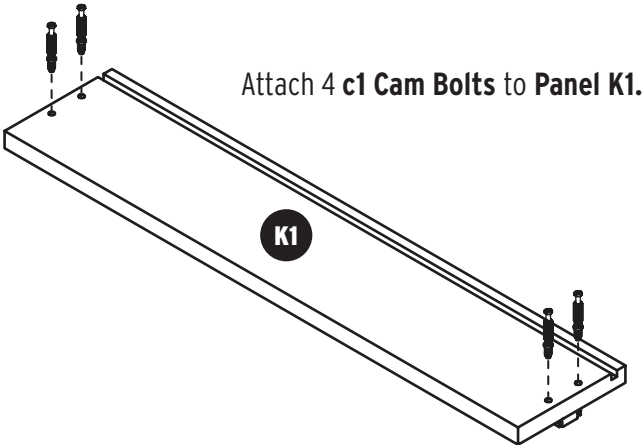

Part Two: Drawers - Middle Drawer

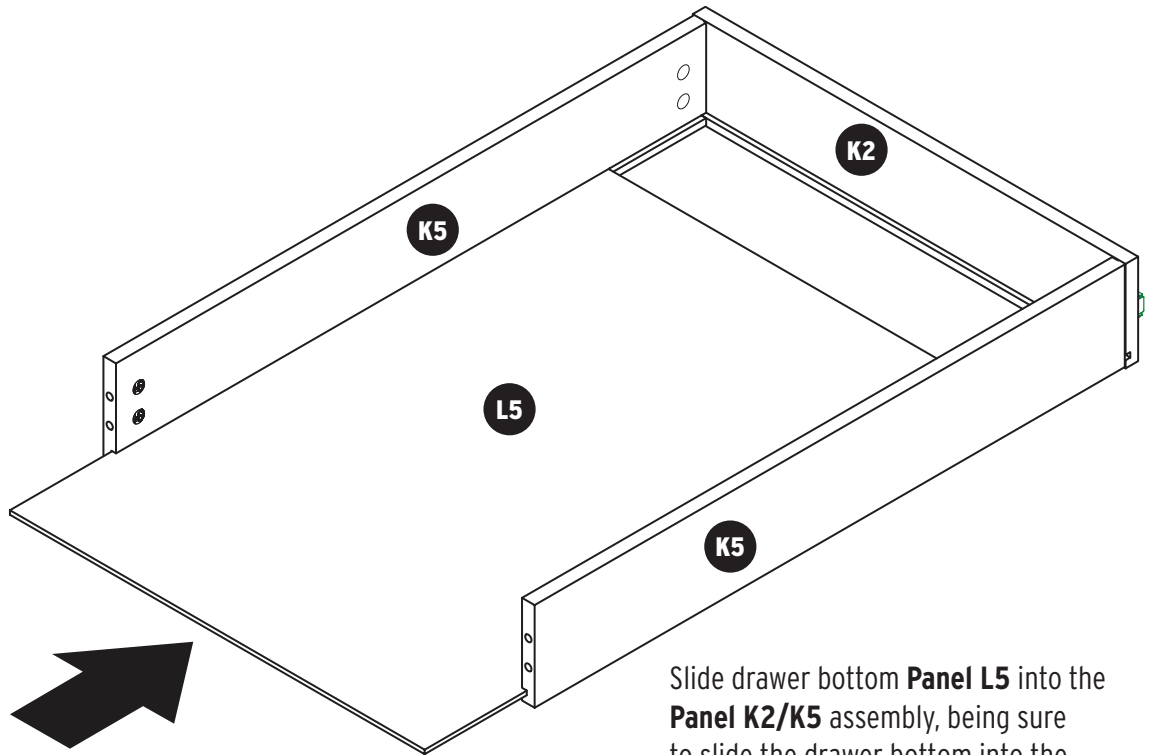
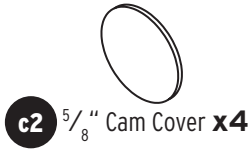

Slide drawer bottom **Panel L5** into the **Panel K2/K5** assembly, being sure to slide the drawer bottom into the grooves on the panels. Tighten cam locks and apply **c2 Cam Covers**.

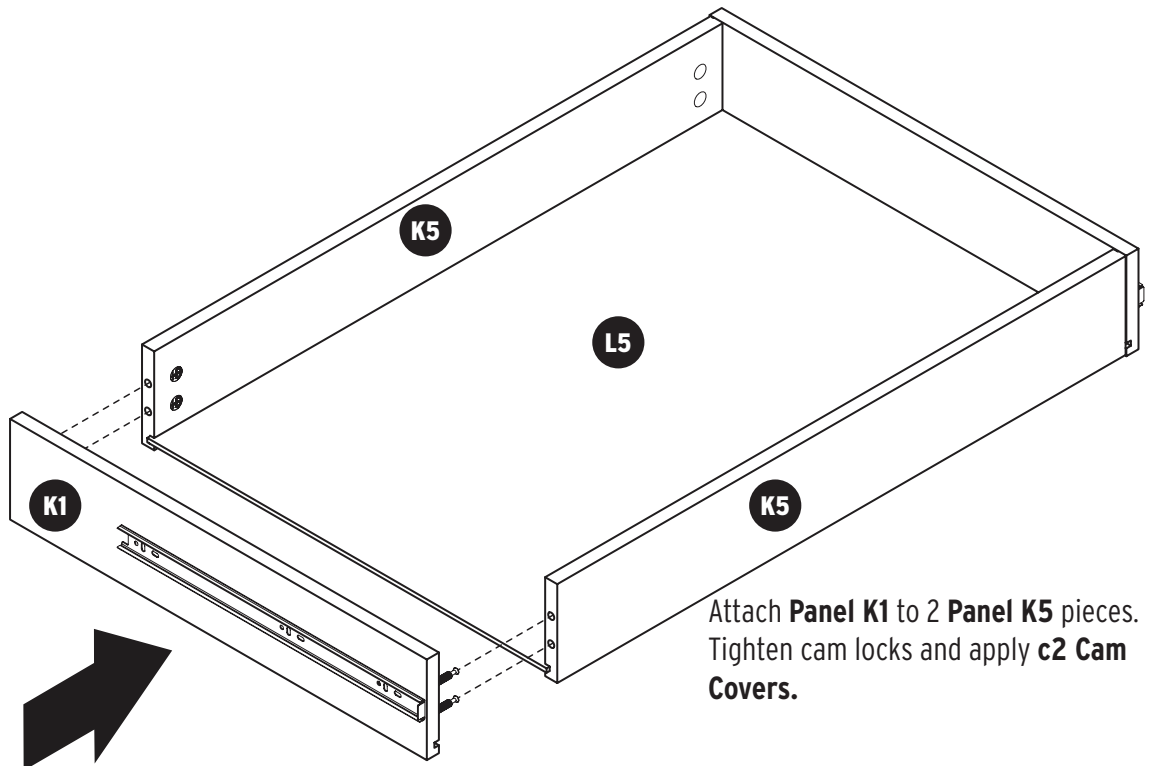

Attach **Panel K1** to 2 **Panel K5** pieces. Tighten cam locks and apply **c2 Cam Covers**.

Part Two: Drawers - Top Drawer

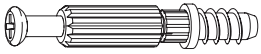

c1 6x35 Cam Bolt **x8**



c2 $\frac{5}{8}$ " Cam Cover **x4**

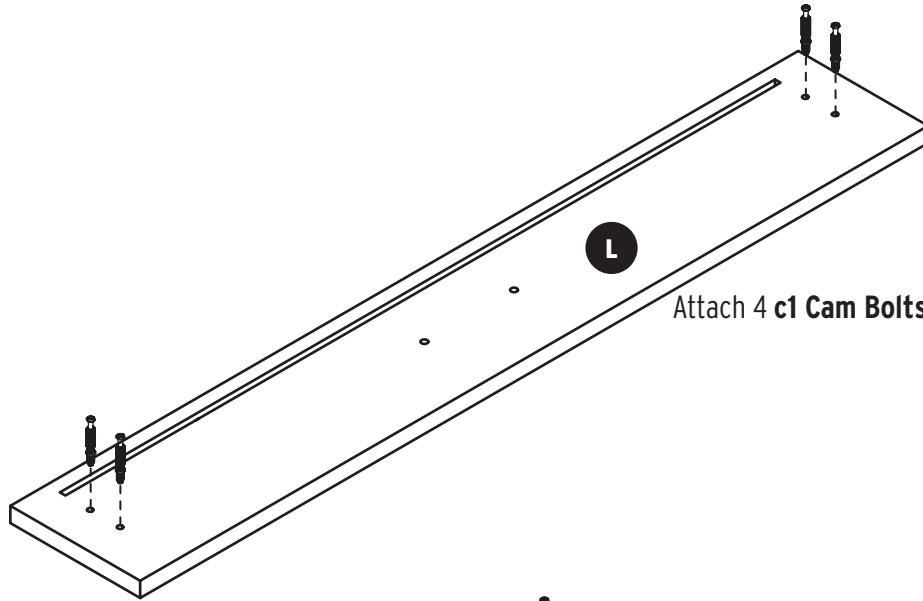

Attach 4 **c1 Cam Bolts** to **Panel L** as shown.

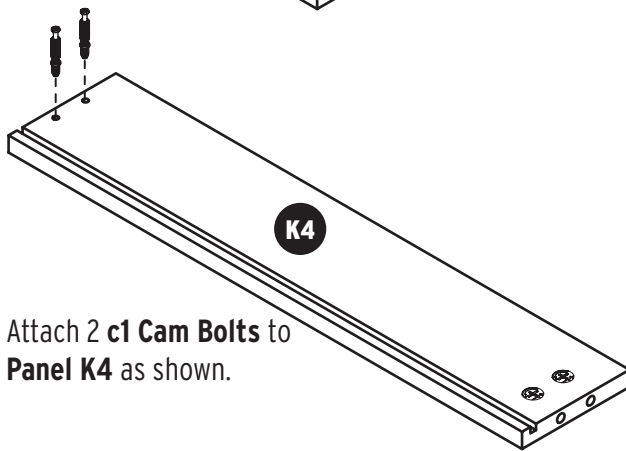

Attach 2 **c1 Cam Bolts** to **Panel K4** as shown.

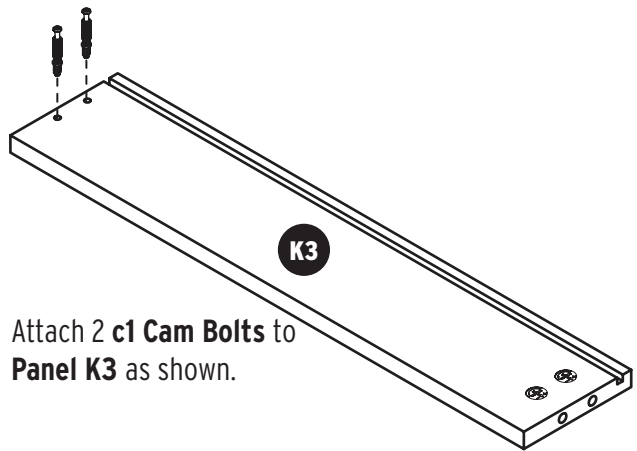

Attach 2 **c1 Cam Bolts** to **Panel K3** as shown.

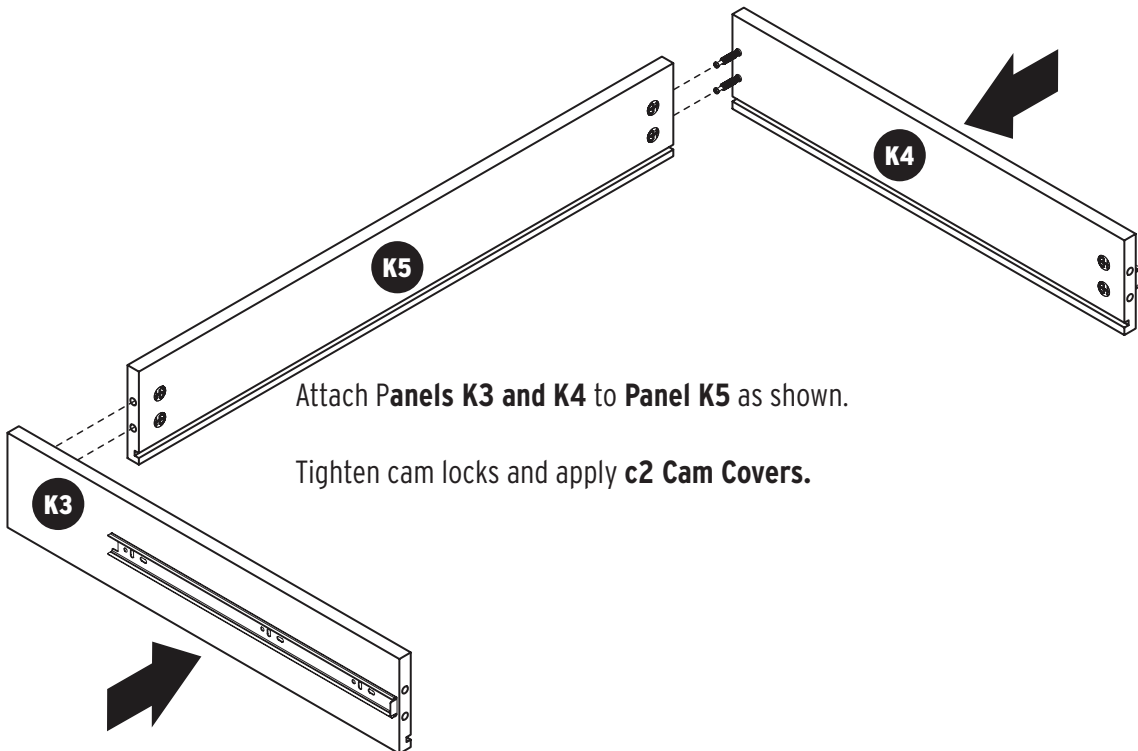

Attach **Panels K3 and K4** to **Panel K5** as shown.

Tighten cam locks and apply **c2 Cam Covers**.

Part Two: Drawers - Top Drawer

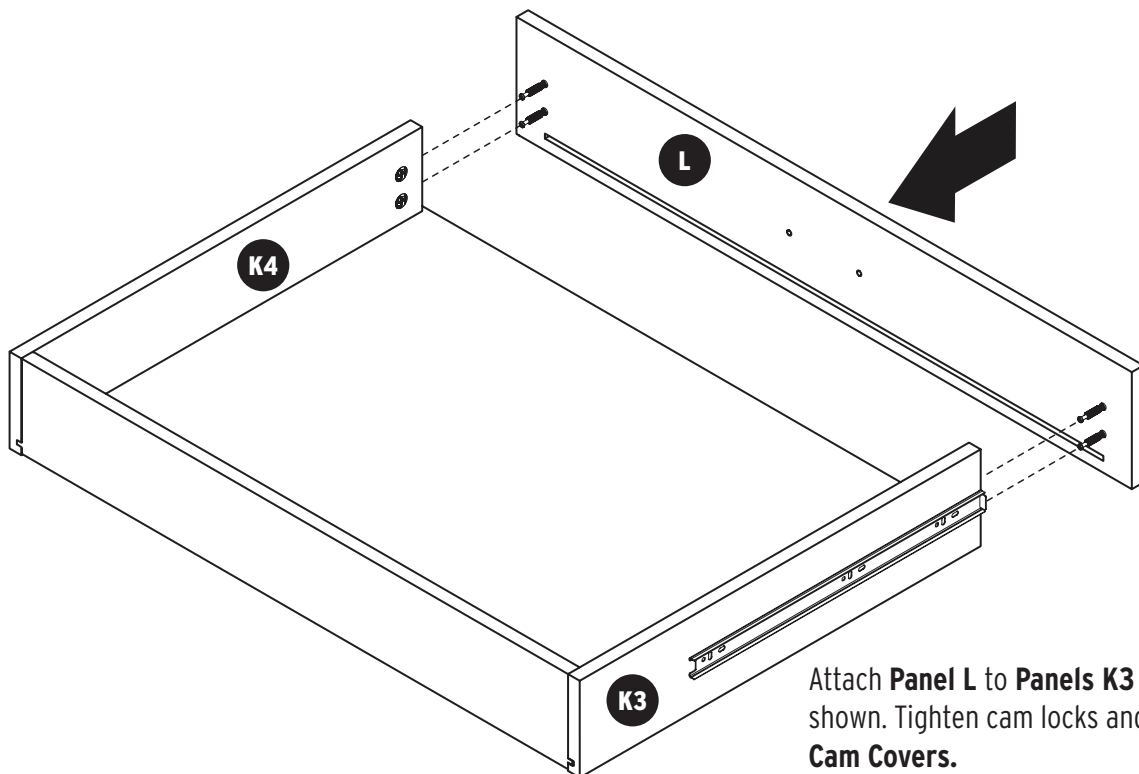
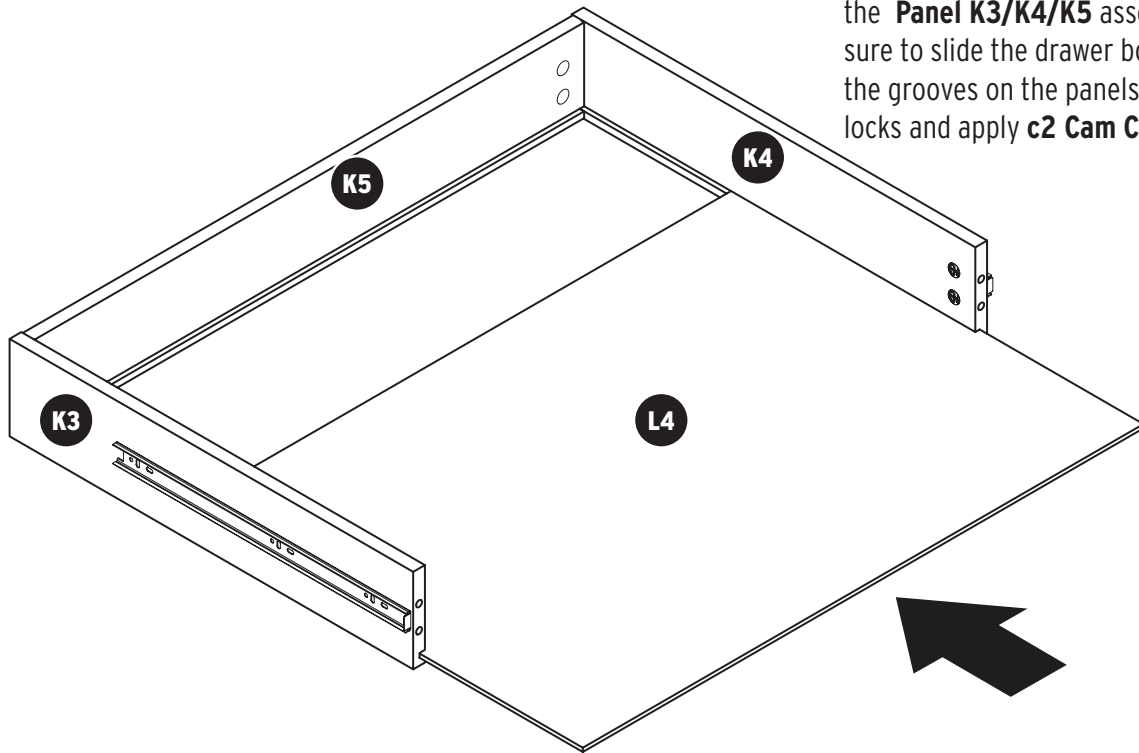

c2 $\frac{5}{8}$ " Cam Cover **x4**

Slide drawer bottom **Panel L4** into the **Panel K3/K4/K5** assembly, being sure to slide the drawer bottom into the grooves on the panels. Tighten cam locks and apply **c2 Cam Covers**.

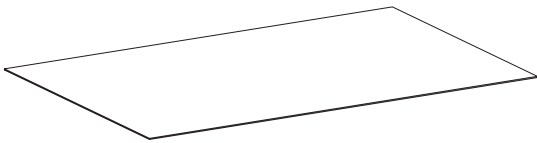

Attach **Panel L** to **Panels K3 and K4** as shown. Tighten cam locks and apply **c2 Cam Covers**.

Part Two: Drawers - Sliding Embroidery Arm Shelf



Adhesive Foam Sheet **x1**

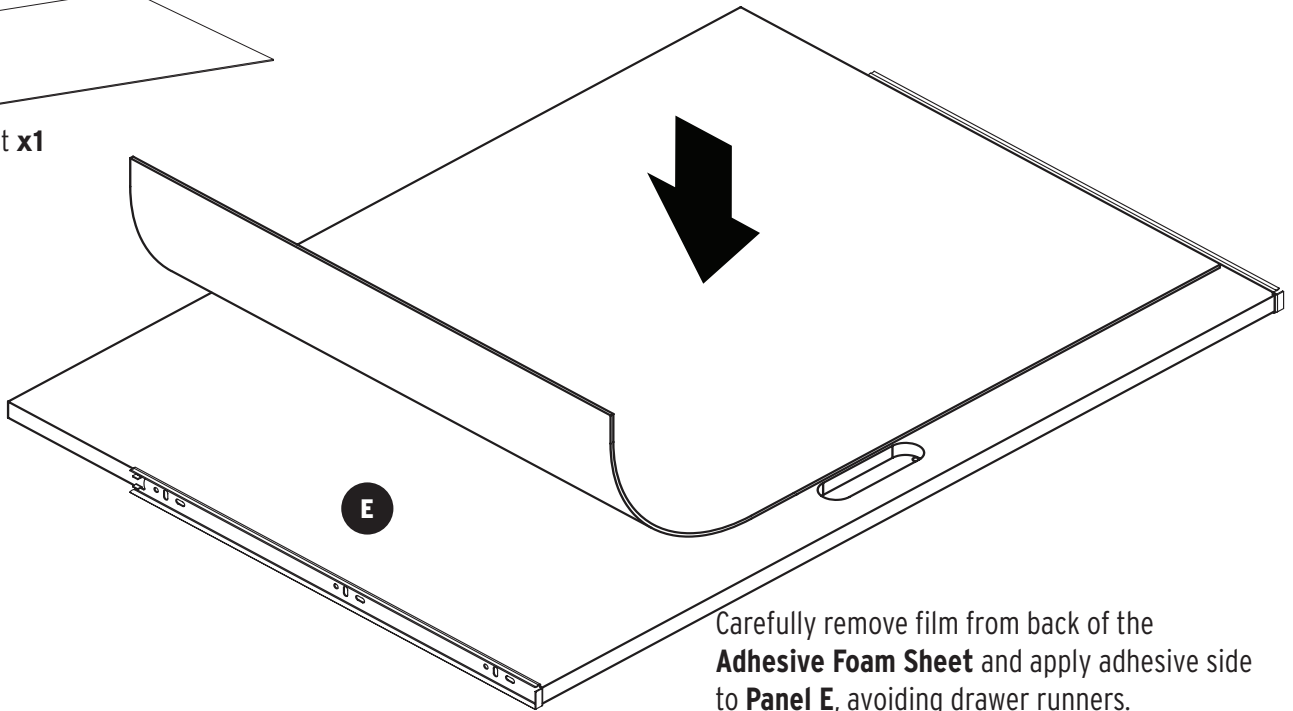

Carefully remove film from back of the **Adhesive Foam Sheet** and apply adhesive side to **Panel E**, avoiding drawer runners.

NOTE: The adhesive is very strong. Be precise when installing!

Slide drawers into cabinet, aligning drawer runners. Be sure that cabinet runners are fully extended, with **ball bearing pieces pulled to the front**.

You must install the drawers in this order:

1. Top Drawer
2. Middle Drawer
3. Bottom Drawer

You may need a friend to help with this step, but it is not required.

Once drawers are installed, attach **h Handles** using **b1 Fix Bolts**.

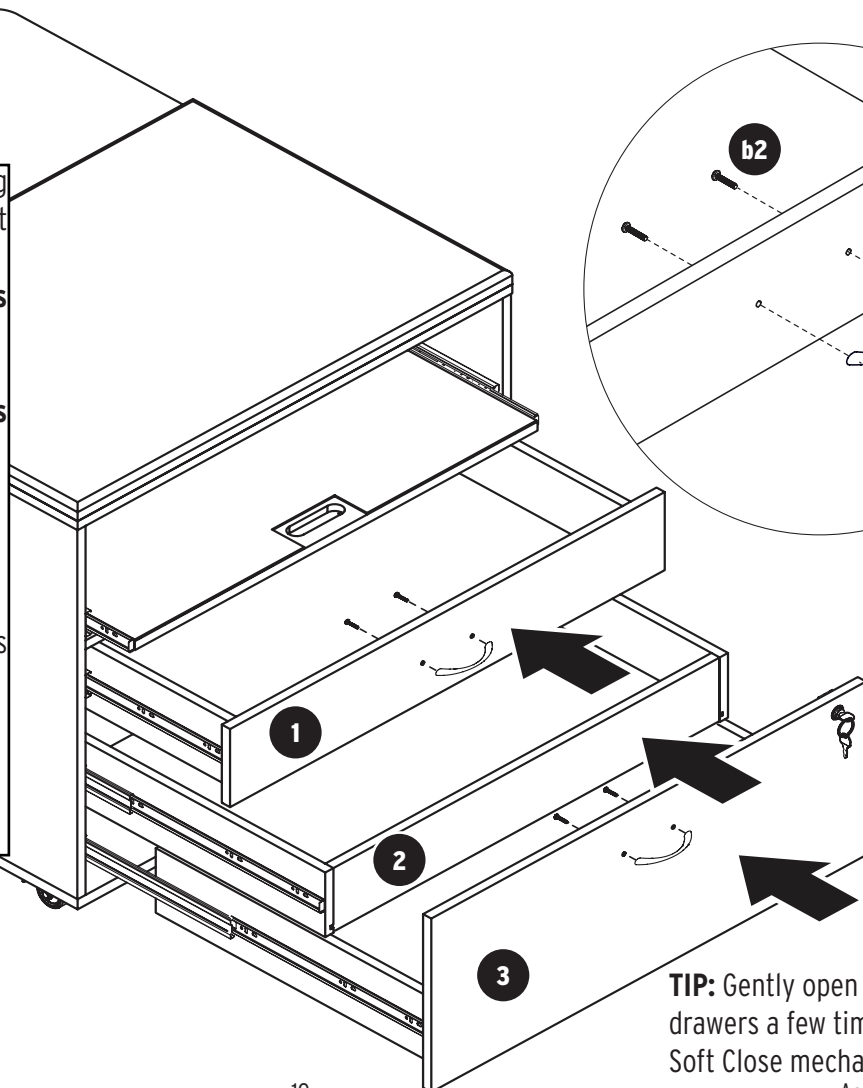

TIP: Gently open and close the drawers a few times to engage the Soft Close mechanism.

Part Two: Drawers - Sliding Embroidery Arm Shelf



s1 3.5x14 Screw **x9**

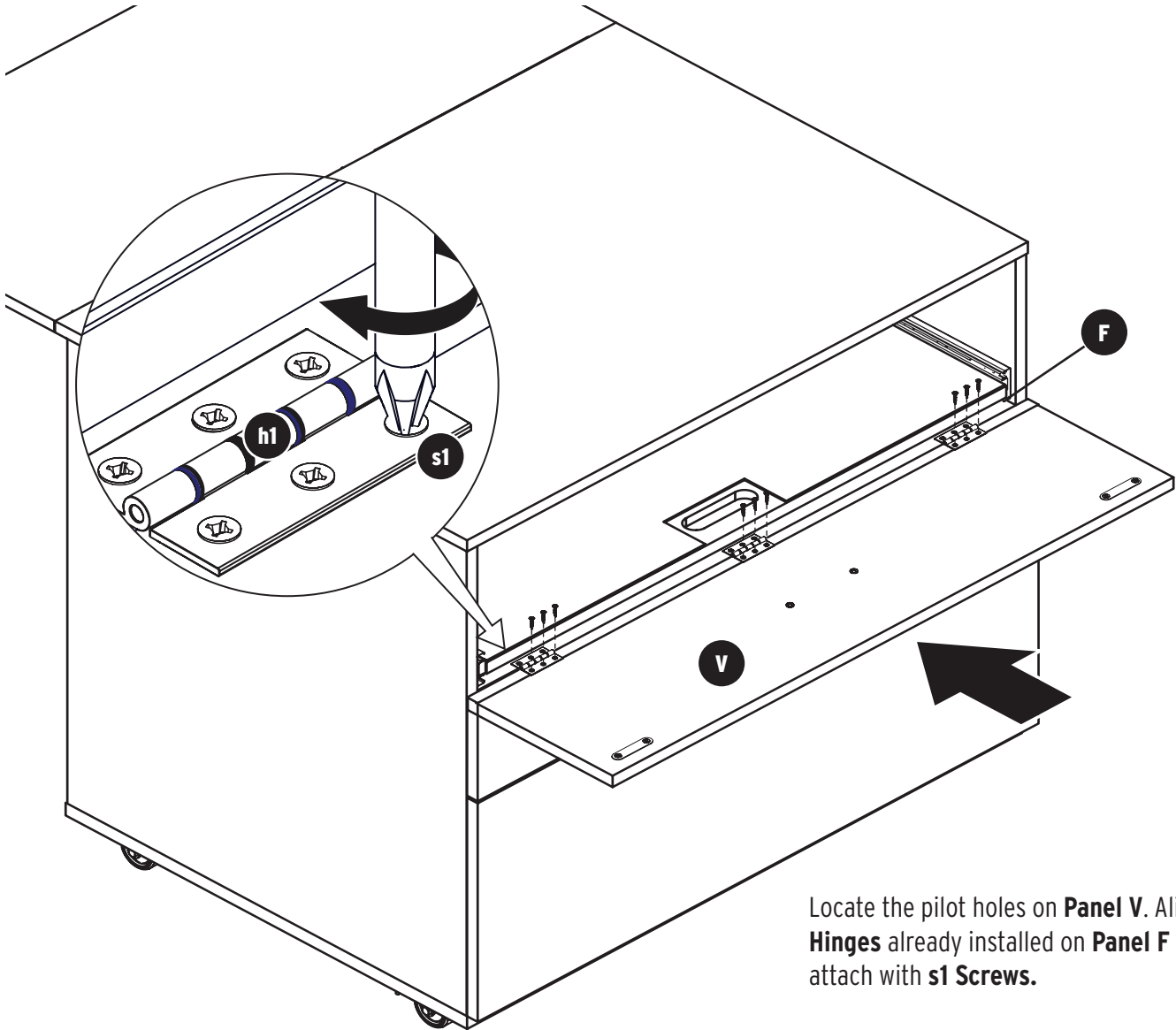

Locate the pilot holes on **Panel V**. Align **Butt Hinges** already installed on **Panel F** and attach with **s1 Screws**.

Part Three: Included Accessories



d2 6x50 Dowel Pin **x70**

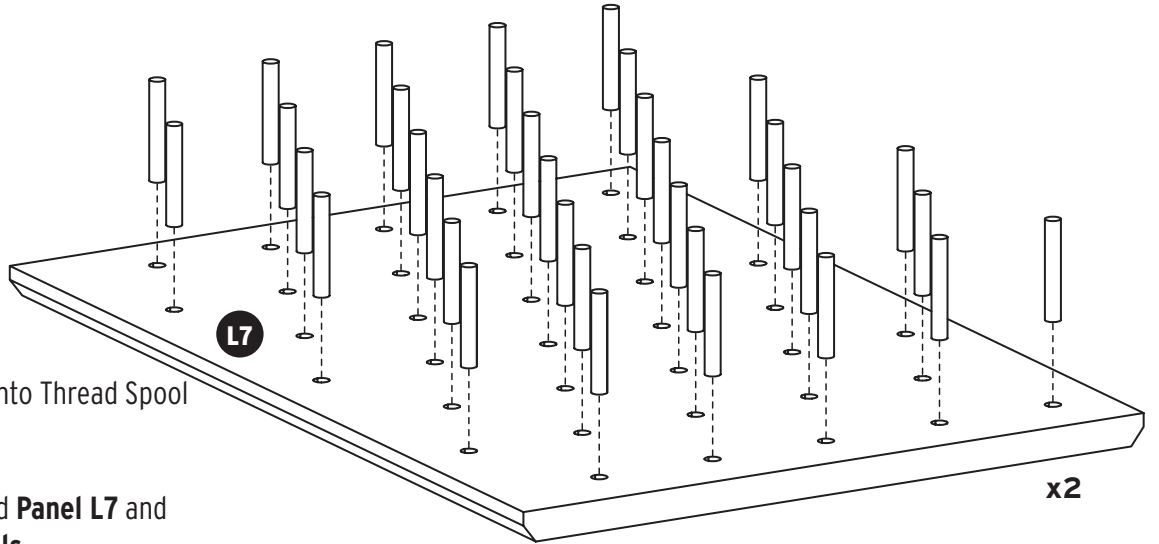

Insert 35 **d2 Dowels** into Thread Spool Holder **Panel L7**.

Repeat with the second **Panel L7** and remaining 35 **d2 Dowels**.

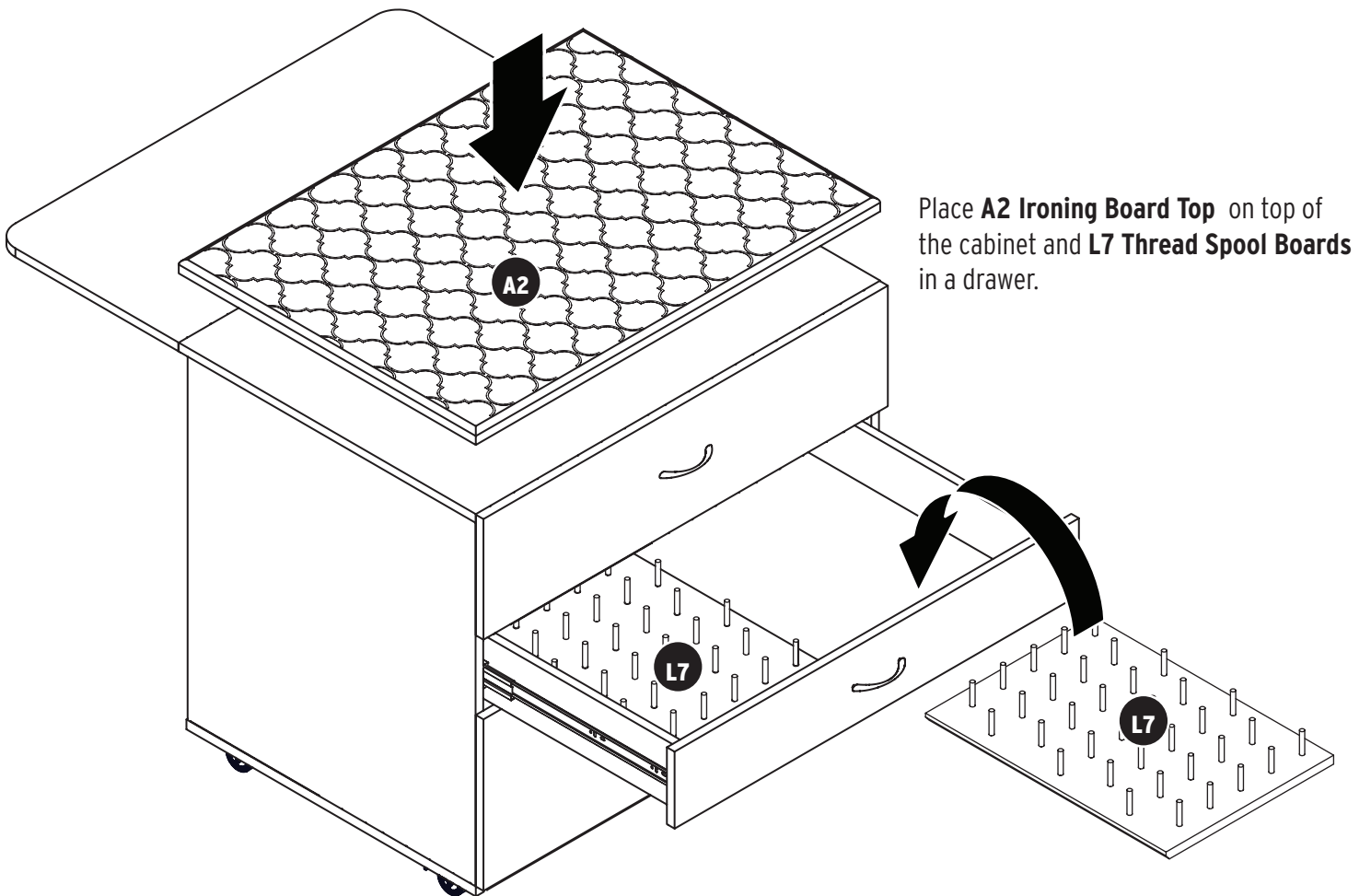

Place **A2 Ironing Board Top** on top of the cabinet and **L7 Thread Spool Boards** in a drawer.



Congratulations! A better sewing experience awaits!



KANGAROO[™]
sewing furniture

LIMITED LIFETIME WARRANTY

Kangaroo[™] Sewing Furniture Limited Lifetime Warranty

WHAT THIS WARRANTY COVERS: Arrow Companies, LLC "Arrow" provides a Limited Lifetime Warranty "Warranty" to the original purchaser of this product against defects in materials or workmanship of furniture components. As used in this Warranty, "defect" means imperfections in components which substantially impair the utility of the product. This Warranty gives you specific legal rights, and you may also have other rights which vary from state to state. Electrical and mechanical components of furniture are warranted for 5 years.

HOW TO GET SERVICE: Simply contact Arrow at 1-800-533-7347 or CS@ArrowSewing.com. When you request Warranty service, you must also present proof of purchase documentation, which includes the date of purchase (detailed receipt), and photos of the product. Arrow will replace any defective part (at its sole option), excluding labor. Replacement parts will be warranted for only the remaining period of the original Warranty.

Replacement parts will be shipped freight prepaid on any initial Warranty claim during first year of Warranty only. Warranty applies only to defects confirmed by Arrow and will be replaced or repaired at Arrow's option. In the event parts are no longer available for a Warranty claim, customer may receive a brand new cabinet at a price equal to 60% off the MSRP of a current comparable model.

WHAT'S NOT COVERED: There is no Warranty coverage for defects or conditions that result from the failure to follow product assembly instructions, information or warnings, misuse or abuse, intentional damage, fire, flood, alteration or modification of the product, or use of the product in a manner inconsistent with its intended use, nor any condition resulting from incorrect or inadequate maintenance, cleaning, care, or neglect, cuts or scratches, caster damage as a result of moving furniture fully loaded or with locked casters, damage resulting from electrical surge or lightning, or use in commercial or education environments. Kangaroo Sewing Furniture is designed for residential use only.

ARROW SHALL HAVE NO LIABILITY for ANY INCIDENTAL OR CONSEQUENTIAL DAMAGES OF ANY KIND and all such damages are EXCLUDED FROM THIS Warranty, such as loss of use, disassembly, transportation, labor, or damage to property on or near the product. Some states do not allow the exclusion or limitation of incidental or consequential damages, so the above limitation or exclusion may not apply to you. The Warranty cannot be transferred to subsequent owners or users of the product, and it shall be immediately void in the event the product is resold, transferred, leased or rented to any third party or person other than the original purchaser.

ADDITIONAL LIMITATIONS: THERE ARE NO OTHER WARRANTIES APPLICABLE TO THIS PRODUCT. Under the laws of certain states, there may be no implied warranties from Arrow and all implied warranties, INCLUDING ANY IMPLIED Warranty OF MERCHANTABILITY OR FITNESS FOR A PARTICULAR PURPOSE are disclaimed where allowed by law. TO THE EXTENT ANY IMPLIED WARRANTIES ARE APPLICABLE, ANY IMPLIED WARRANTIES, INCLUDING ANY IMPLIED Warranty OF MERCHANTABILITY OR FITNESS FOR A PARTICULAR PURPOSE, ARE LIMITED IN DURATION TO THE DURATION OF THIS EXPRESS Warranty or the minimum period allowed by law, whichever is shorter. Some states do not allow limitations on how long an implied Warranty lasts, so the above limitation may not apply to you. This limited Warranty gives you specific legal rights. This limited Warranty does not, in any way, affect the rights given to you by law.

REGISTER YOUR PRODUCT: Original purchaser should register the purchase online at www.ArrowSewing.com/Warranty.

SEW IN COMFORT. SEW LONGER.[™]



Accessories to Complete Your Sewing Studio

Custom Insert

Enhance your sewing experience with a custom acrylic sewing insert! Custom acrylic sewing inserts are designed to fill the gap between your sewing machine and sewing cabinet's lift opening to create a flush, ergonomic surface for flat bed sewing. To ensure a perfect fit, custom acrylic sewing inserts are built specifically for your sewing machine and sewing cabinet combination. Say hello to happy wrists, straighter stitches, and an elevated sewing experience!

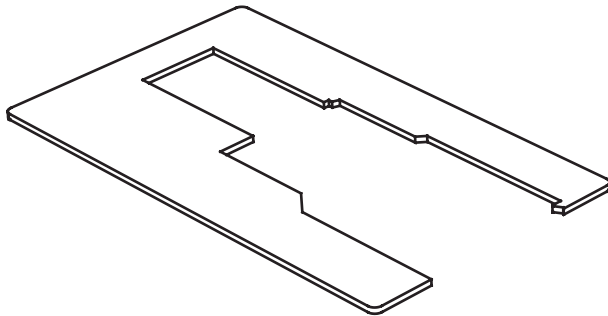

Insert

Arrow Sewing Chairs

Arrow's #1 Rated Height Adjustable Sewing Chair is a must have accessory for your dream sewing room! Cute, comfortable and convenient - our lovable sewing chairs feature vibrant sewing themed patterns, 360 swivel access and lumbar support for long hours at your workstation. Don't look now, but under every seat cushion is a hidden storage compartment to store your notions and patterns! Available in 10 colors to perfectly match your sewing sanctuary!

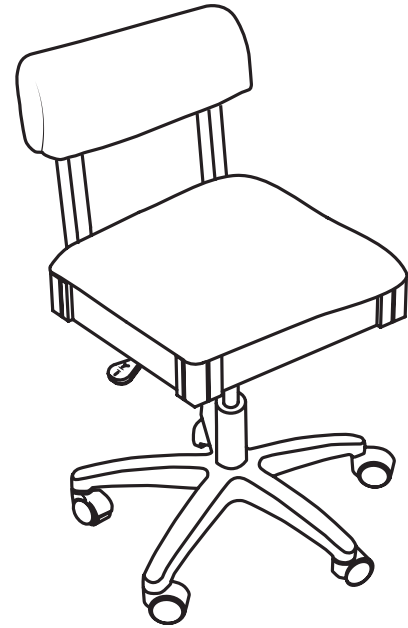

Height Adjustable Sewing Chair

P.O. Box 410 Elkhorn, WI 53121
1-800-533-7347 Ext. 1
CS@ArrowSewing.com
www.ArrowSewing.com

10-21